

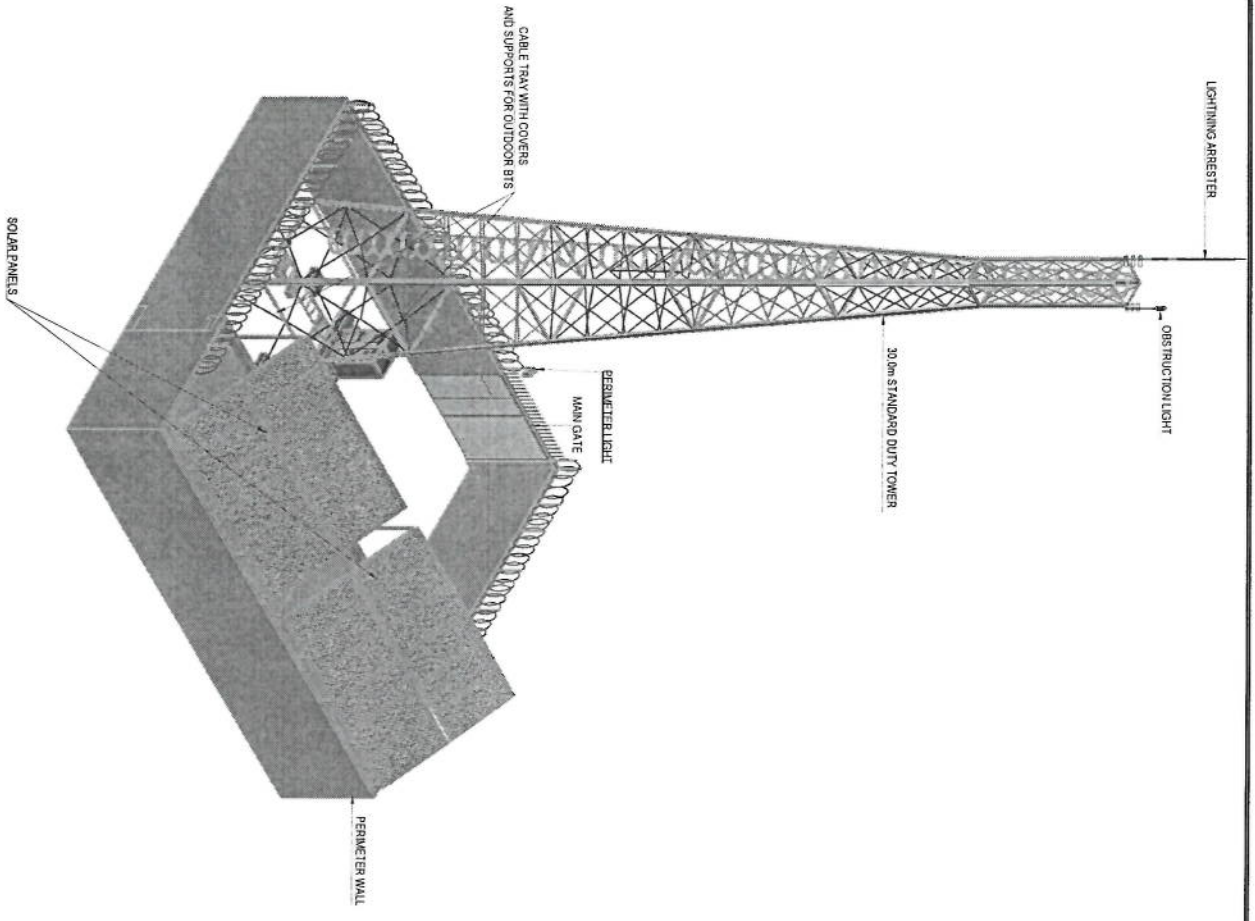

**STANDARD DRAWING  
DETAILED DESIGN DRAWING**

*Standard*



TOWER HEIGHT 30.0m, SD TOWER



**PERSPECTIVE**  
SCALE: 1:100





*Handwritten signature or initials in blue ink.*

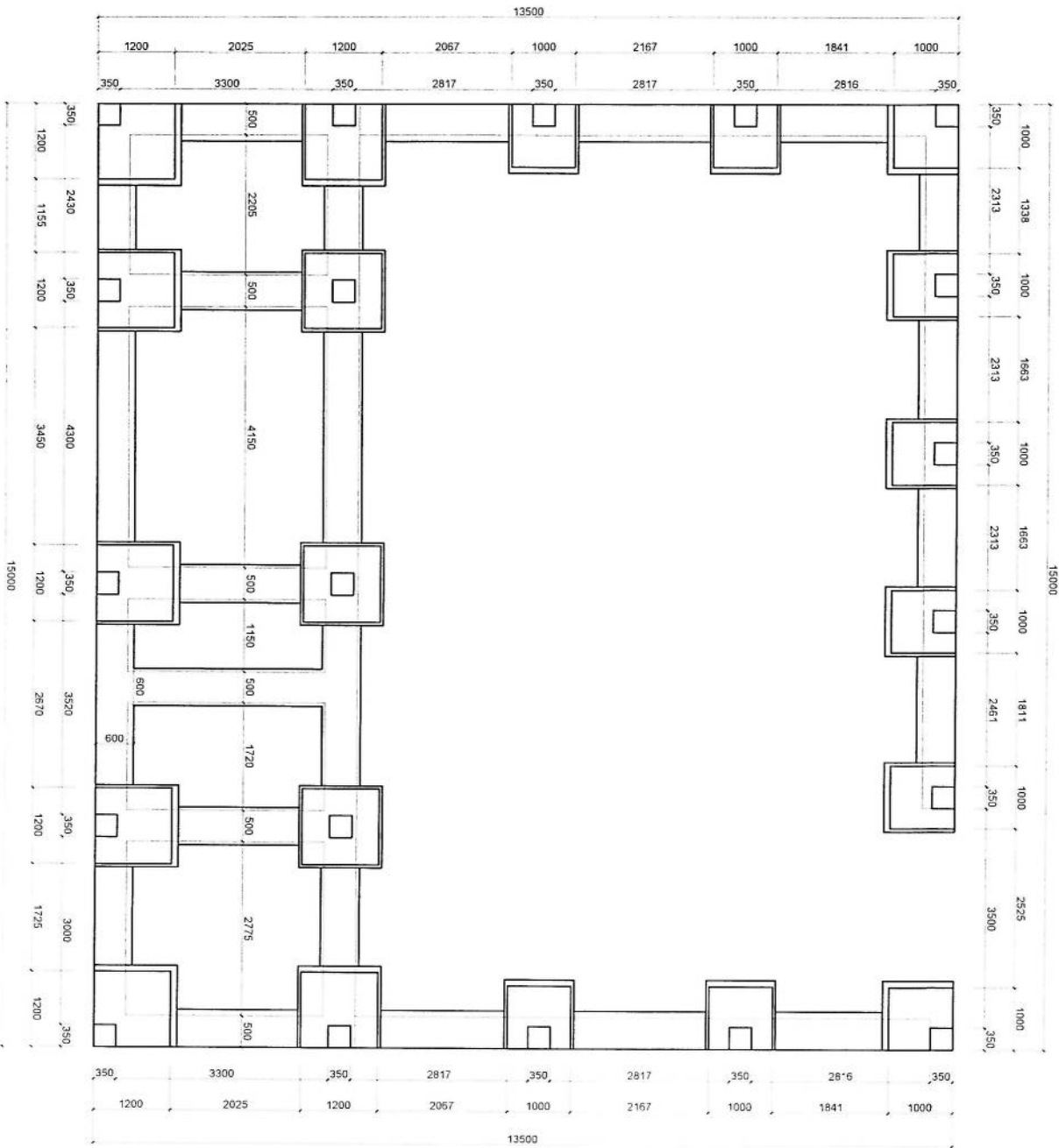

FOUNDATION PLAN  
SCALE: 1:125

PHASE 2

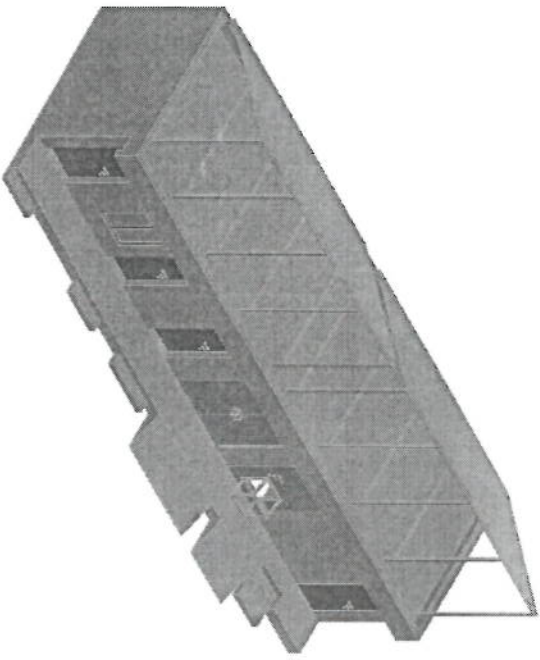

**PERSPECTIVE**  
SCALE  
MIS

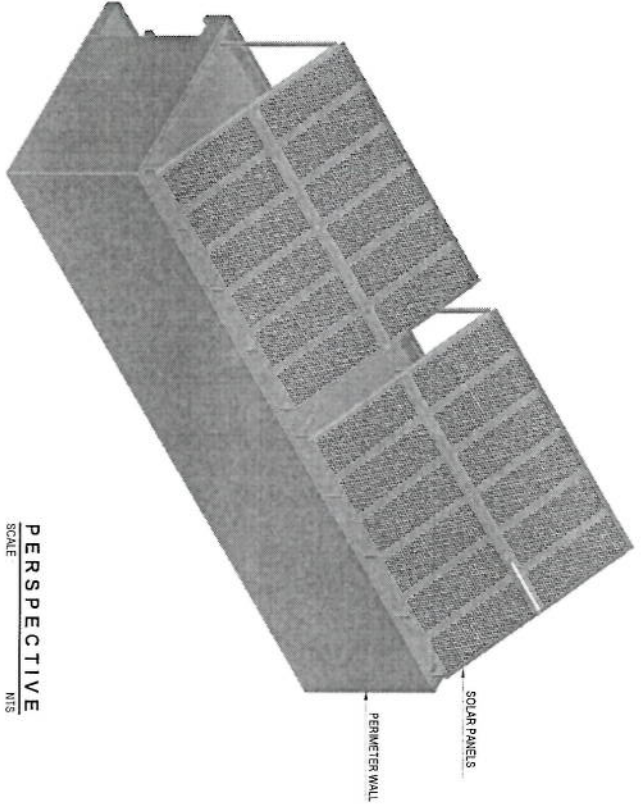

PERIMETER WALL

SOLAR PANELS

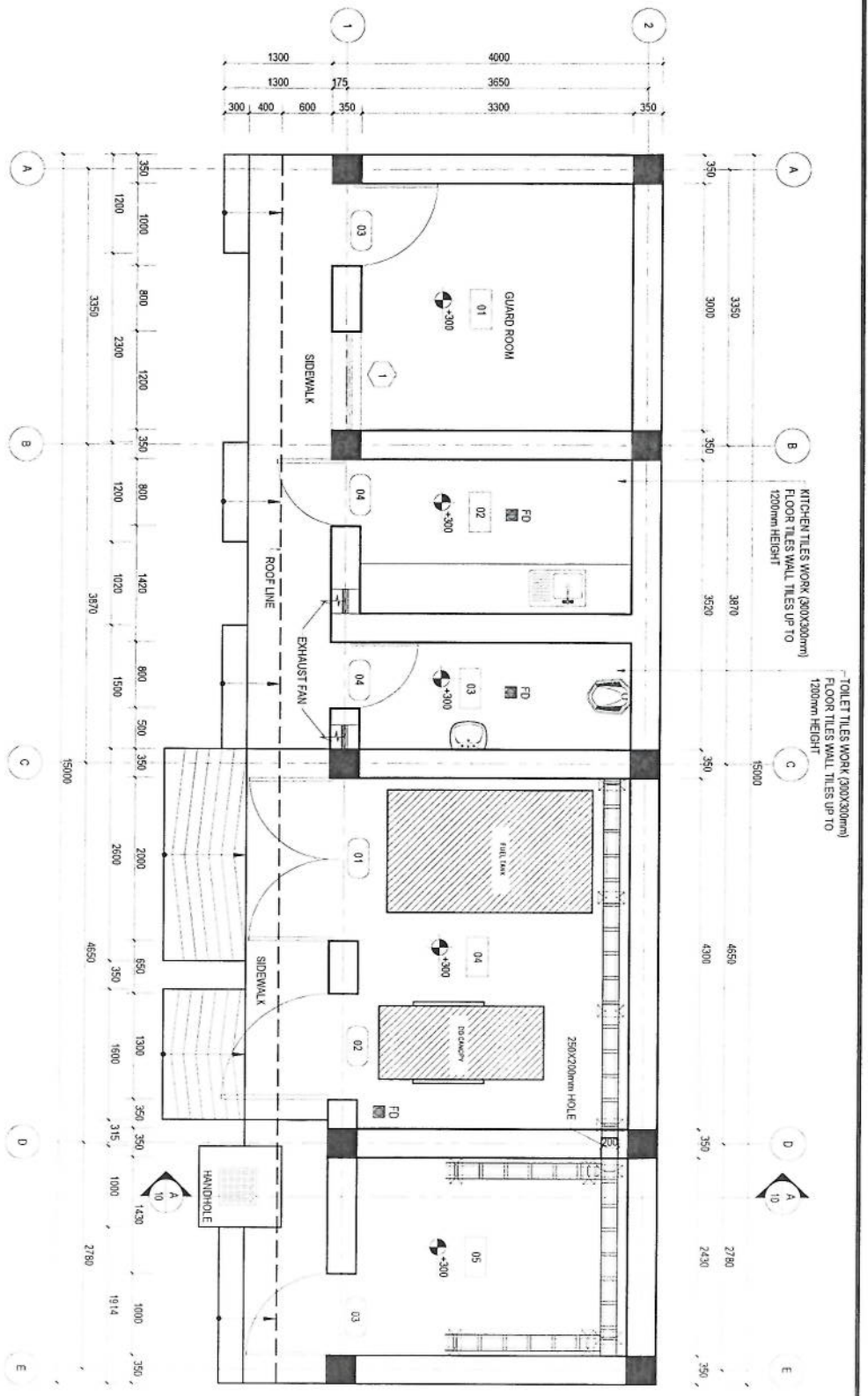

NOTE  
1. ALL DIMENSIONS ARE IN MM AND ANGLES IN DEGREES UNLESS OTHERWISE NOTED.

**FLOOR PLAN**  
SCALE 1:80

- HATCH LEGEND**
- PLAIN CONCRETE CEMENT
  - BRICK WORK
  - OVERHEAD STRUCTURE
  - REINFORCEMENT COLUMN
- ROOM LEGEND**
- 01 GUARD ROOM
  - 02 KITCHEN
  - 03 TOILET
  - 04 FUEL TANK AND DG ROOM
  - 05 BATTERIES ROOM



*[Handwritten signature]*



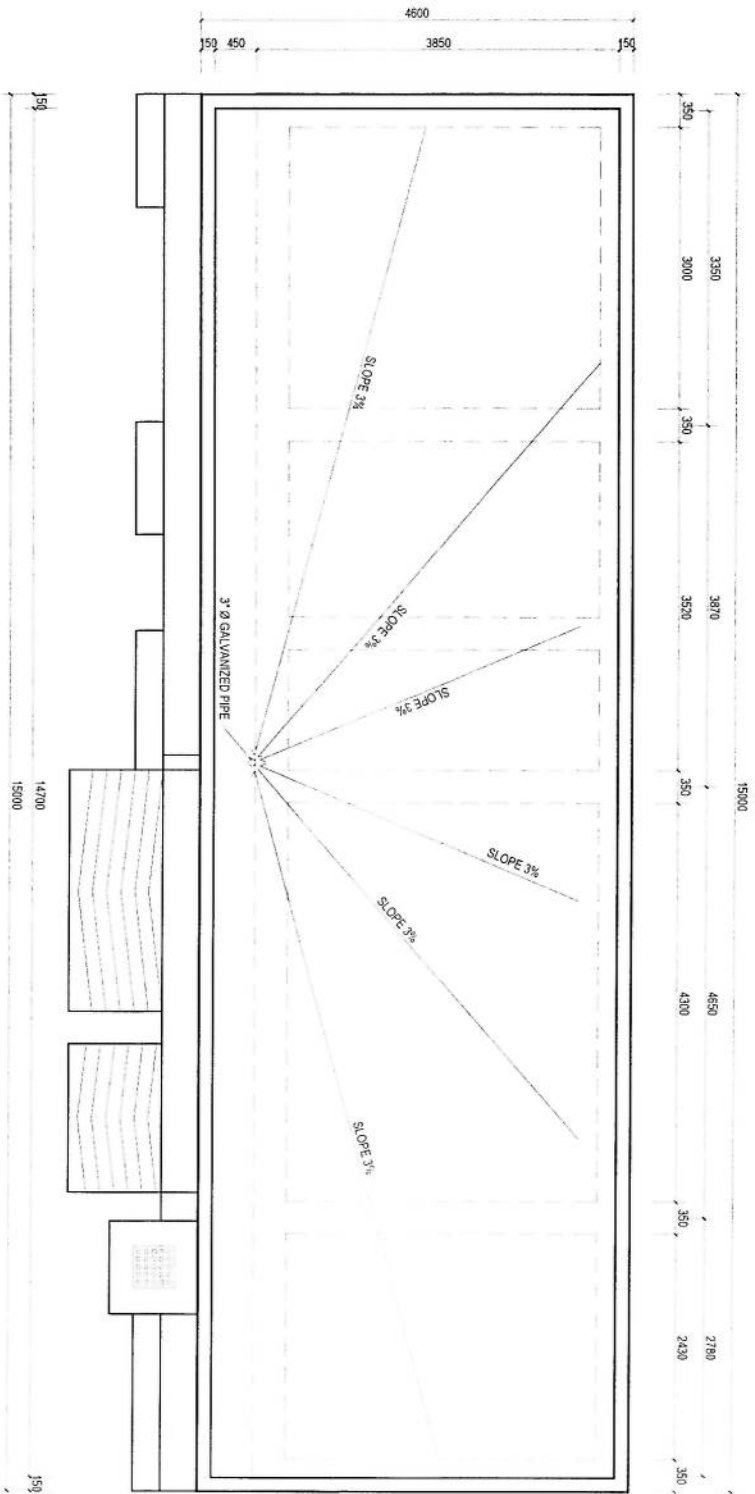

**ROOF PLAN**  
SCALE 1:100

- NOTE
1. ALL DIMENSIONS ARE IN MM AND ANGLES IN DEGREES UNLESS OTHERWISE NOTED.
  2. ROOF SLOPE 3%

*[Handwritten signature]*

*Handwritten signature*

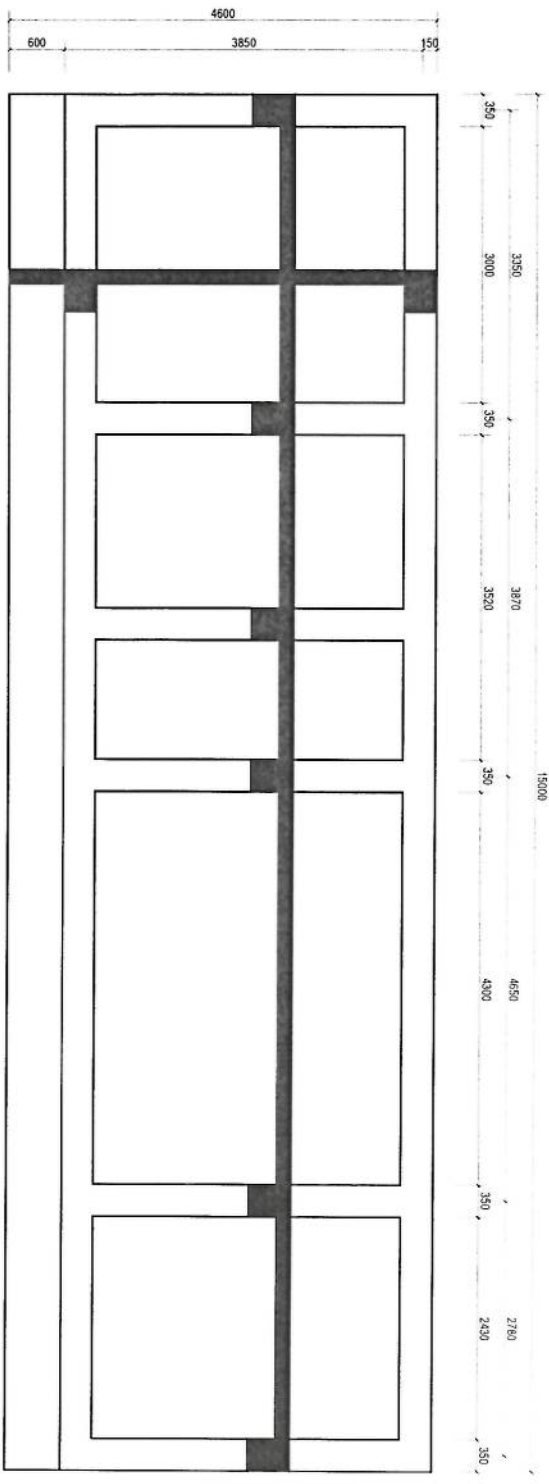
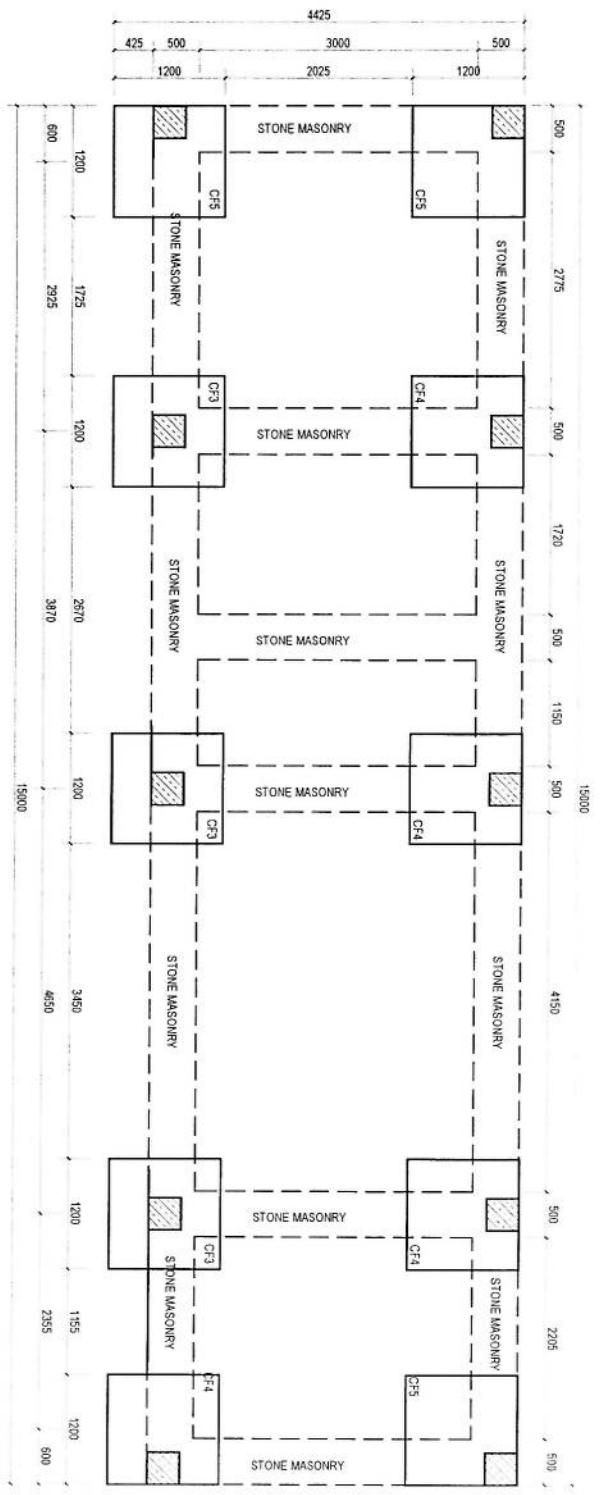

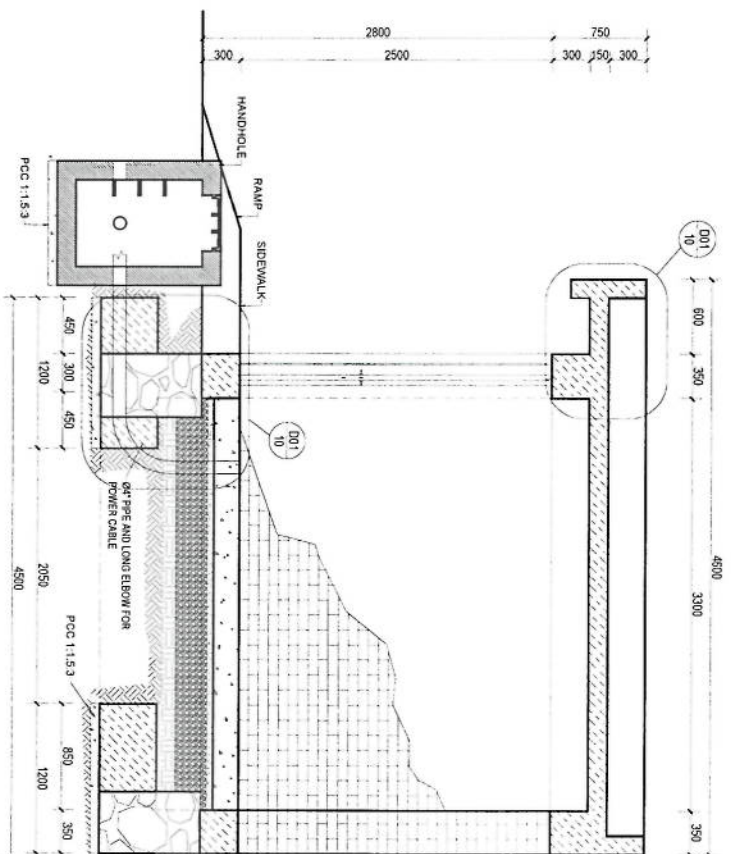

**SECTION H-H**  
SCALE: 1/80

TOP OF THE PARAPET WALL  
+3550  
TOP OF THE ROOF SLAB  
+3250  
BOTTOM OF THE ROOF BEAM  
+3100  
BOTTOM OF THE ROOF BEAM  
+2800

TOP OF THE FLOOR SURFACE  
+300  
GRADE LEVEL  
+0.00  
BOTTOM OF THE RUBBLE FOUNDATION  
-800

RCC SLAB  
PCC  
MOISTURE INSULATION  
PCC WITH SLOPE 3%

CAP  
3" Ø GALVANIZED PIPE

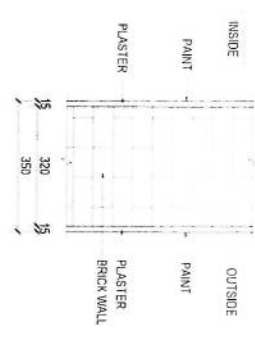

**WALL DETAIL**  
SCALE: 1/20

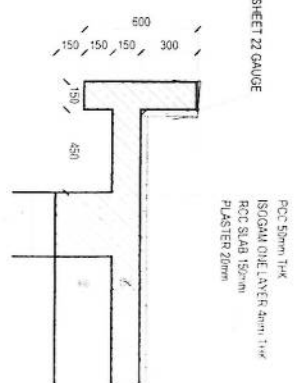

**ROOF DETAIL D02**  
SCALE: 1/40

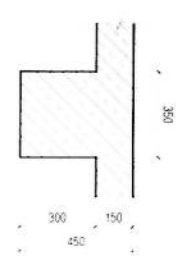

**ROOF DETAIL D01**  
SCALE: 1/30

**GUTTER PIPE DETAIL**  
SCALE: 1/5

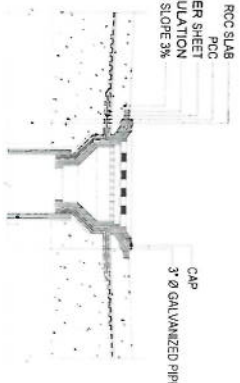

NOTE  
ALL DIMENSIONS ARE IN MM AND ANGLES IN DEGREES UNLESS OTHERWISE NOTED.

**HATCH LEGEND**

- PLAIN CONCRETE CEMENT
- REINFORCEMENT CONCRETE CEMENT
- OVERHEAD STRUCTURE
- BRICK SECTION
- BRICK PLAN
- ELEVATION
- REINFORCEMENT COLUMN
- REINFORCEMENT DOWN

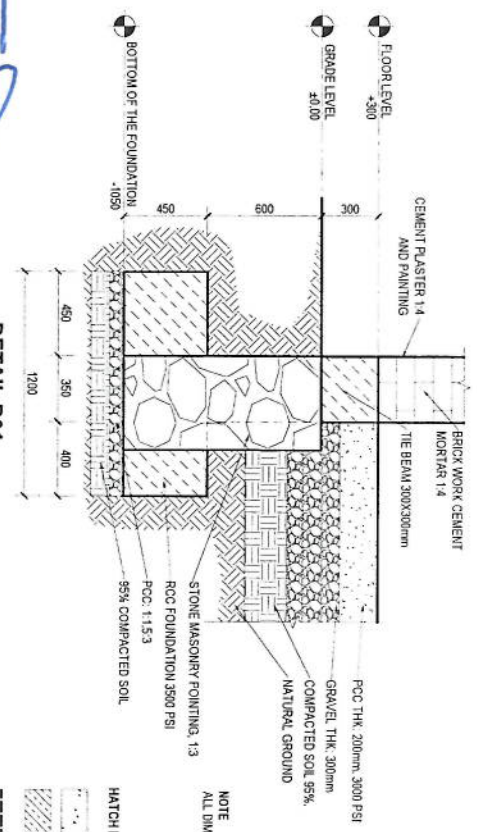

**DETAIL D01**  
SCALE: 1/40

*Handwritten signature in blue ink.*

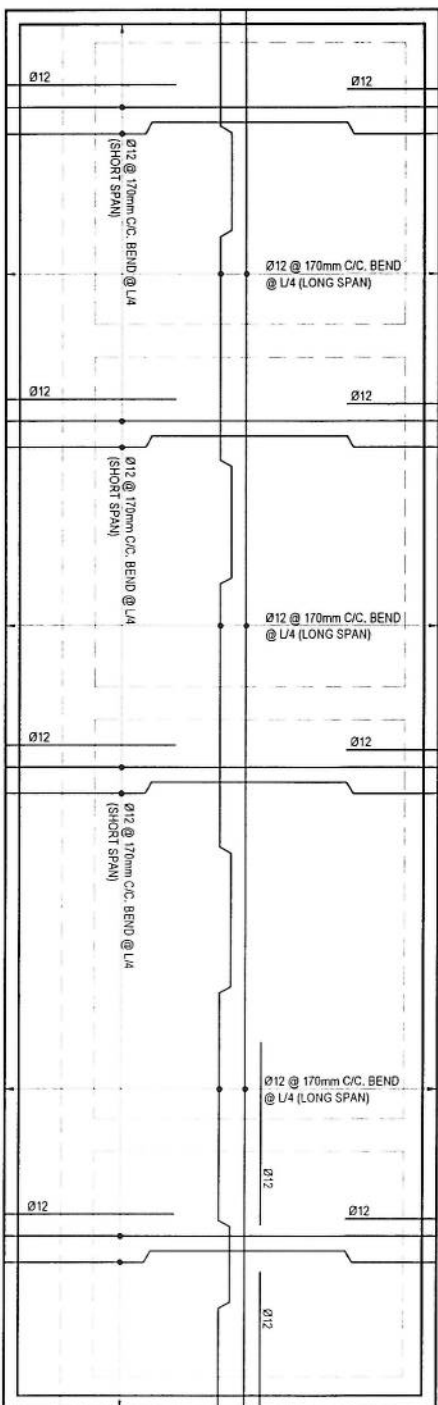

**ROOF SLAB REINFORCEMENT PLAN**  
SCALE: 1/80

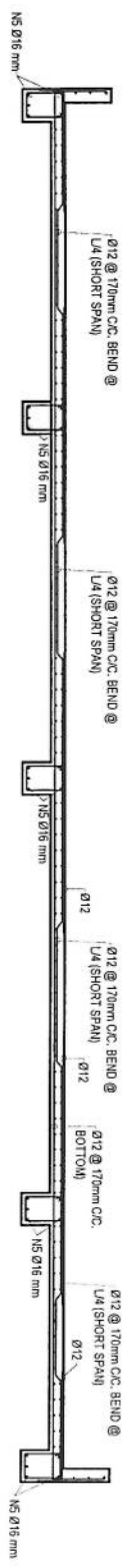

**ROOF SLAB SECTION**  
SCALE: 1/80

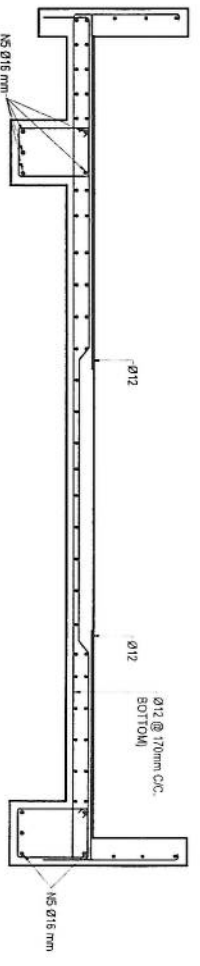

**SECTION G-G**  
SCALE: 1/40

- NOTE**
1. CONCRETE MIX RATIO SHOULD BE SUCH THAT 28 DAYS STRENGTH MUST BE 4-3000 psi.
  2. DEFORMED BAR OF GRADE 60 (Y-60000 psi).
  3. MINIMUM CLEAR COVER TO REINFORCING STEEL: 30 mm.
  4. VIBRATOR, MIXTURE MACHINE SHOULD BE USED IN CONCRETE CASTING.
  5. CONSTRUCTION SHOULD BE DONE WITH CLOSED SUPERVISION OF A.M.C.C. SITE ENGINEER.

*Handwritten signature or initials in blue ink.*





*Handwritten signature or initials in blue ink.*

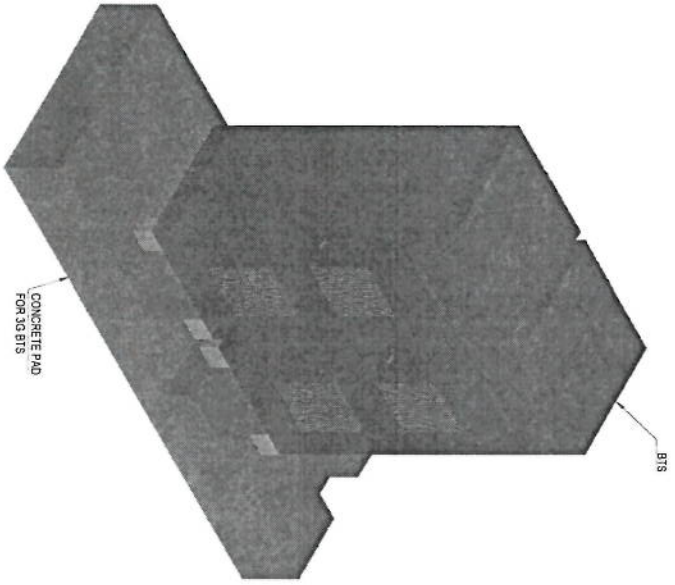

**3D VIEW PLAN**  
SCALE: 1/4"=1'-0"

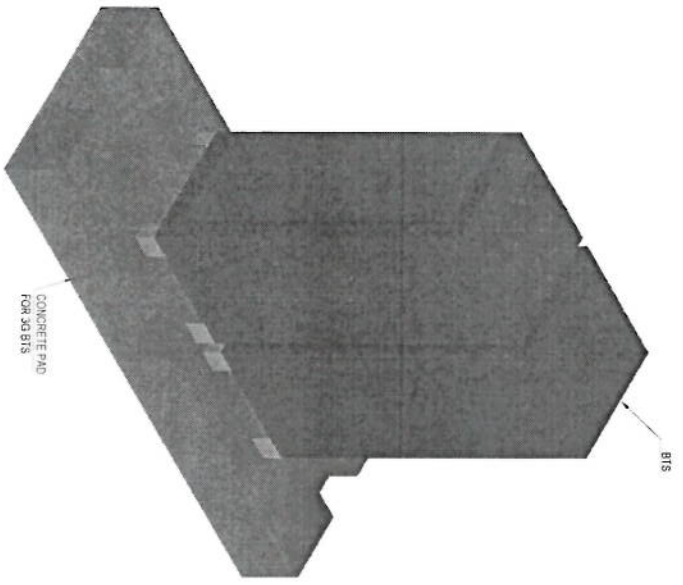

**3D VIEW PLAN**  
SCALE: 1/4"=1'-0"

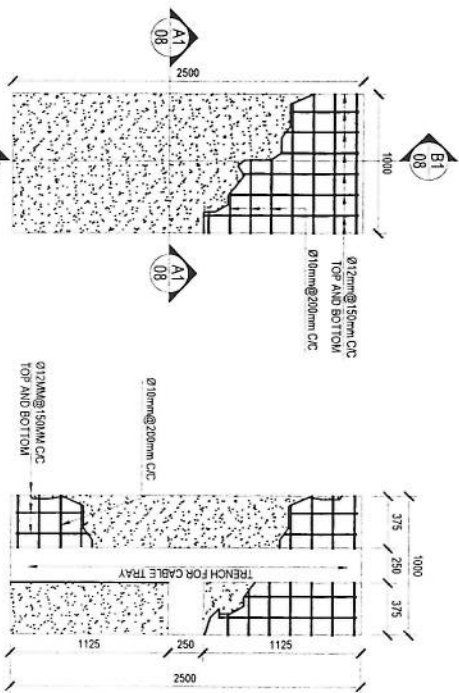

**OUT DOOR BTS CONCRETE PAD DETAIL**  
SCALE 1:50M

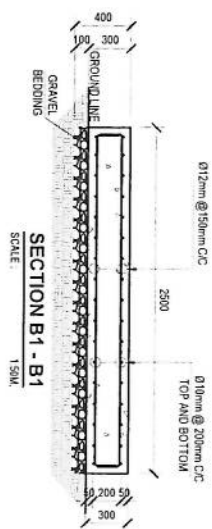

**SECTION B1 - B1**  
SCALE 1:50M

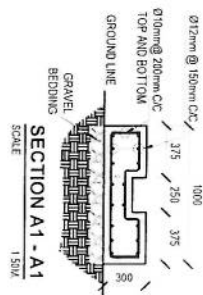

**SECTION A1 - A1**  
SCALE 1:50M

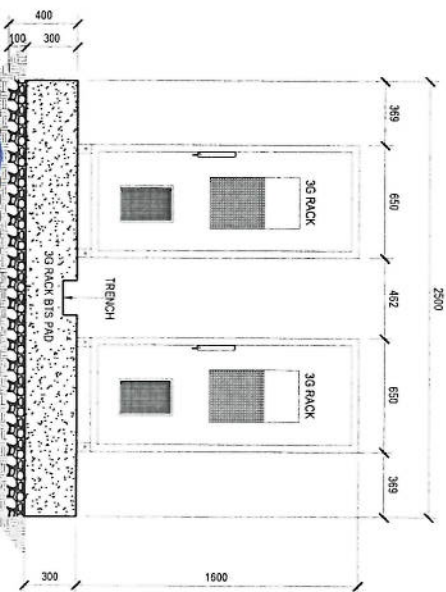

**OUT DOOR BTS RACKS & PAD FRONT VIEW**  
SCALE 1:40M

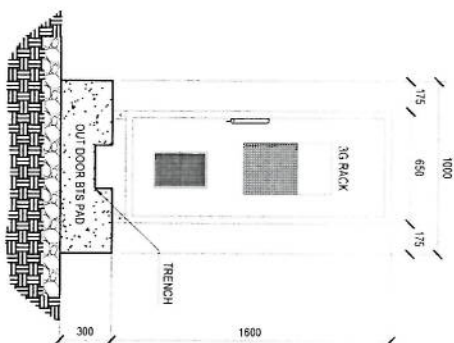

**OUT DOOR BTS RACKS & PAD SIDE VIEW**  
SCALE 1:40M

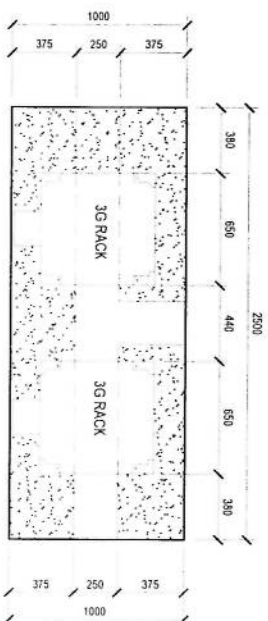

**OUT DOOR BTS RACKS & PAD TOP PLAN**  
SCALE 1:40M

*Handwritten signature and initials in blue ink.*

REVISION RECORDS			
REVISION NO.	DATE	DESCRIPTION	

LEGEND:

 24 Gage GI Sheet

 use 4" Galvanized Pipe

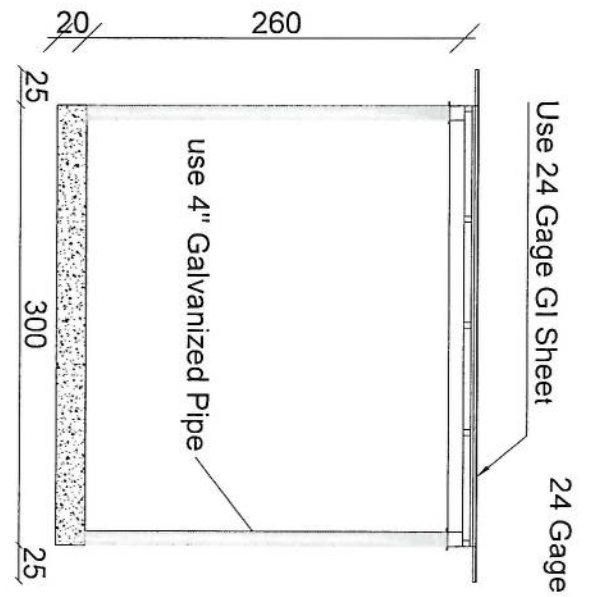

Section BB

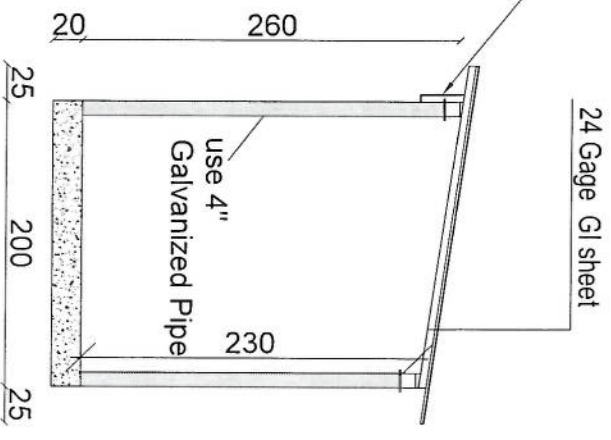

Section AA

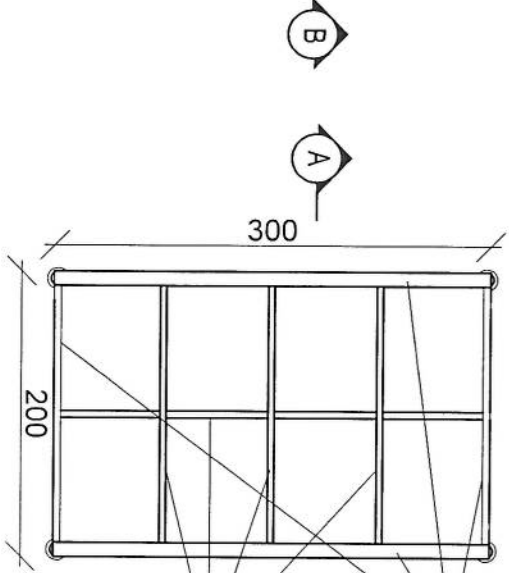
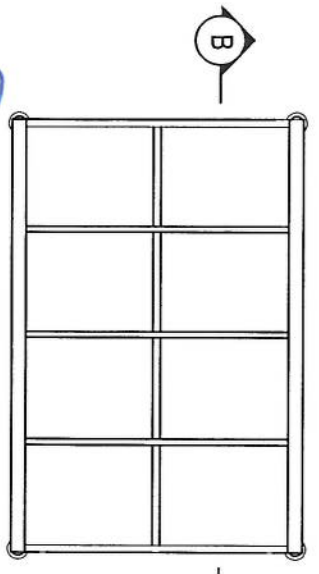

use (100 x 100) 2mm thick channel

use (50 x 100) 2mm thick channel

17 SUN SHELTER FOR ZTE BTS

21 REF. A117

SCALE: 1:50

PROJECT TITLE / NO: GSM SITES

DRAWING TITLE: SUN SHELTER FOR ZTE BTS

DRAWN BY: CIVIL TEAM

CHECKED BY:

APPROVED BY:

SCALE: 1:50

ACTUAL DATE: 17/04/2021

ISSUE DATE: DRG.NO: 17

OWNER: AFGHAN TELECOM

Scaleam Telecommunication Company

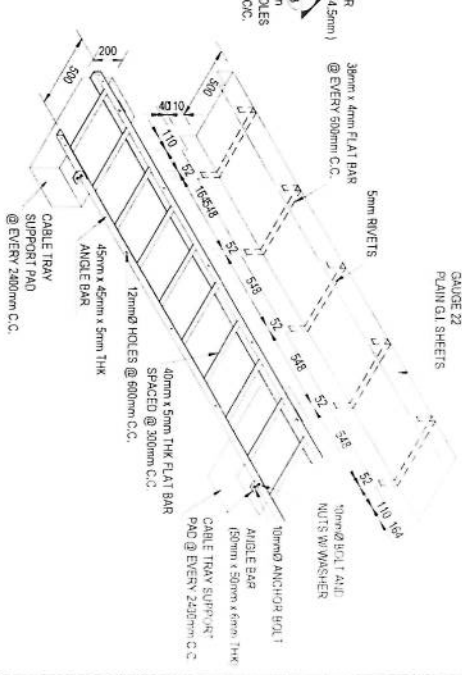
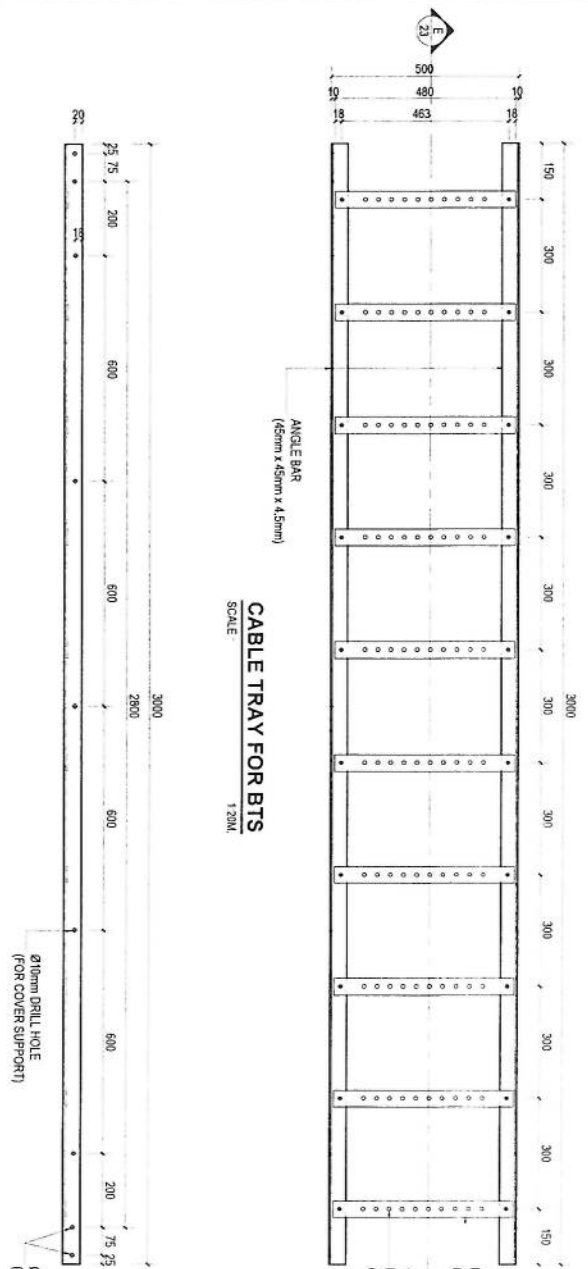

**CABLE TRAY FOR BTS**  
SCALE: 1:20M

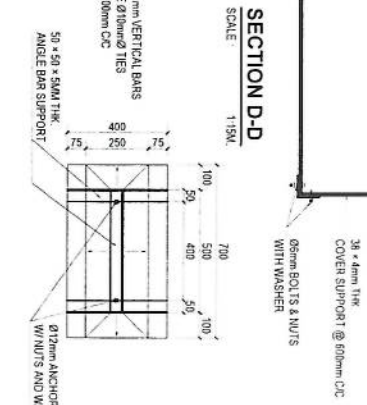
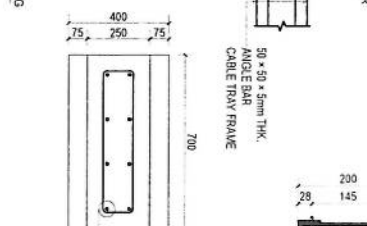
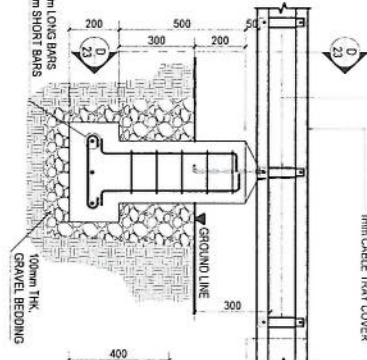
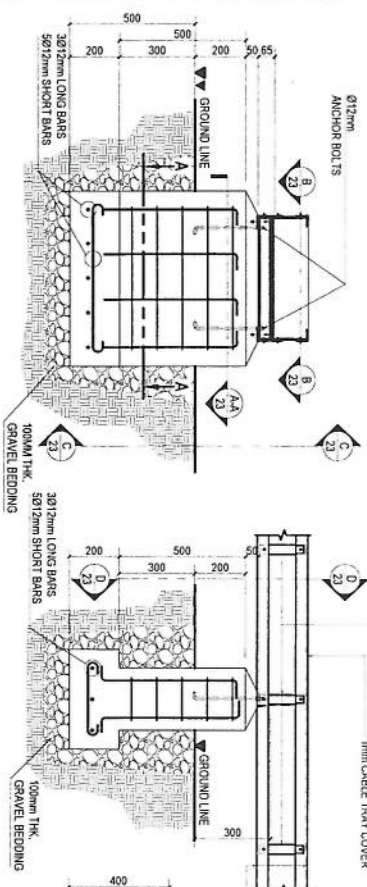

*Handwritten signature and initials in blue ink.*

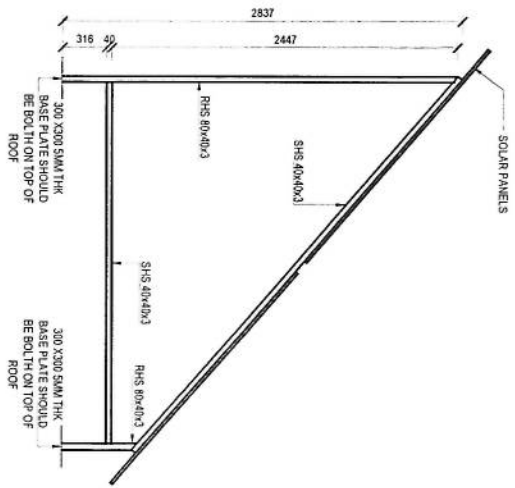
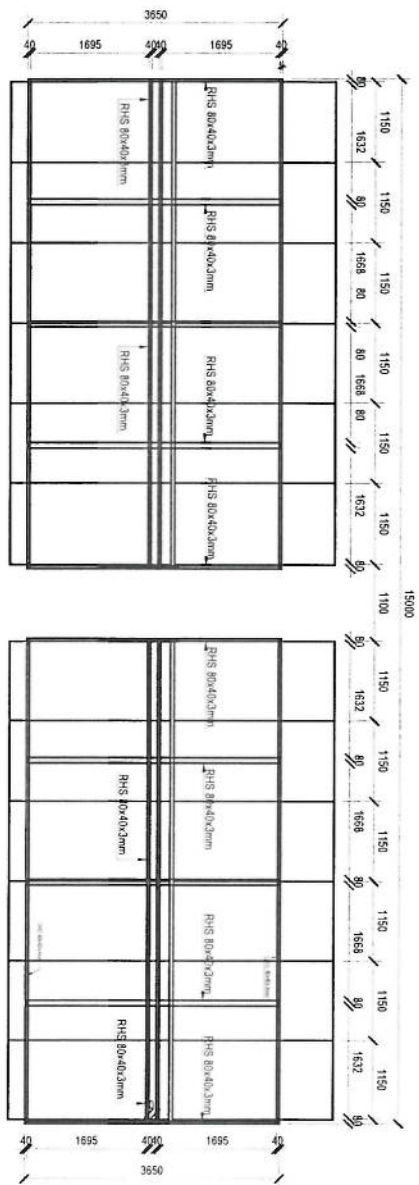

*[Handwritten signature]*





روی این پایه ها نصب گردد

KITCHEN TILES WORK (300X300mm)  
FLOOR TILES WALL TILES UP TO  
1200mm HEIGHT

TOILET TILES WORK (300X300mm)  
FLOOR TILES WALL TILES UP TO  
1200mm HEIGHT

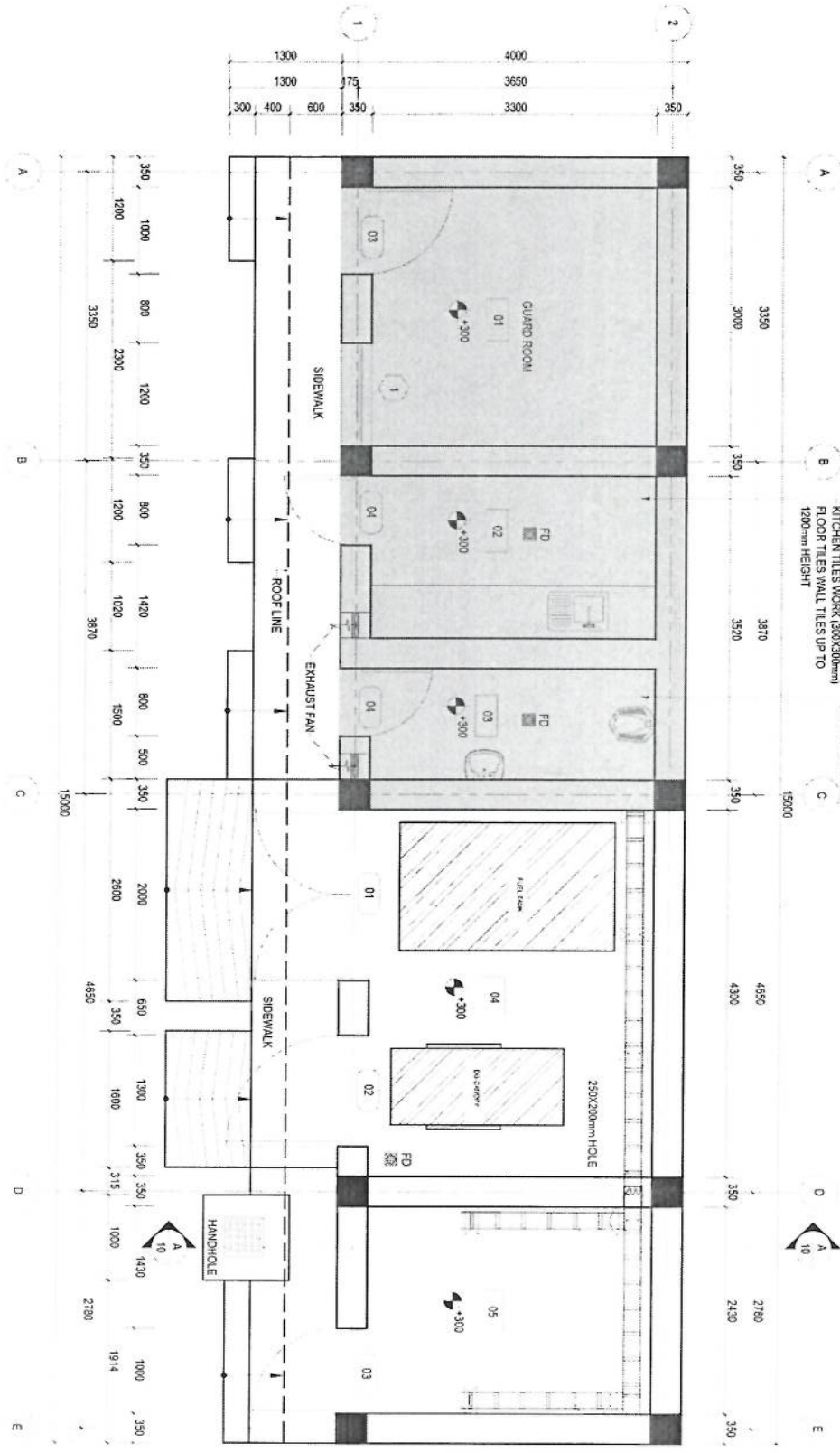

NOTE  
1. ALL DIMENSIONS ARE IN MM AND ANGLES IN DEGREES UNLESS OTHERWISE NOTED.

FLOOR PLAN  
SCALE 1:80

HATCH LEGEND

- PLAN CONCRETE CEMENT
- BRICK WORK
- OVERHEAD STRUCTURE
- REINFORCEMENT COLUMN

ROOM LEGEND

- 01 GUARD ROOM
- 02 KITCHEN
- 03 TOILET
- 04 FUEL TANK AND DG ROOM
- 05 BATTERIES ROOM

D/W DOWN  
FD FLOOR DRAIN  
ELEVATION

*[Handwritten signature]*



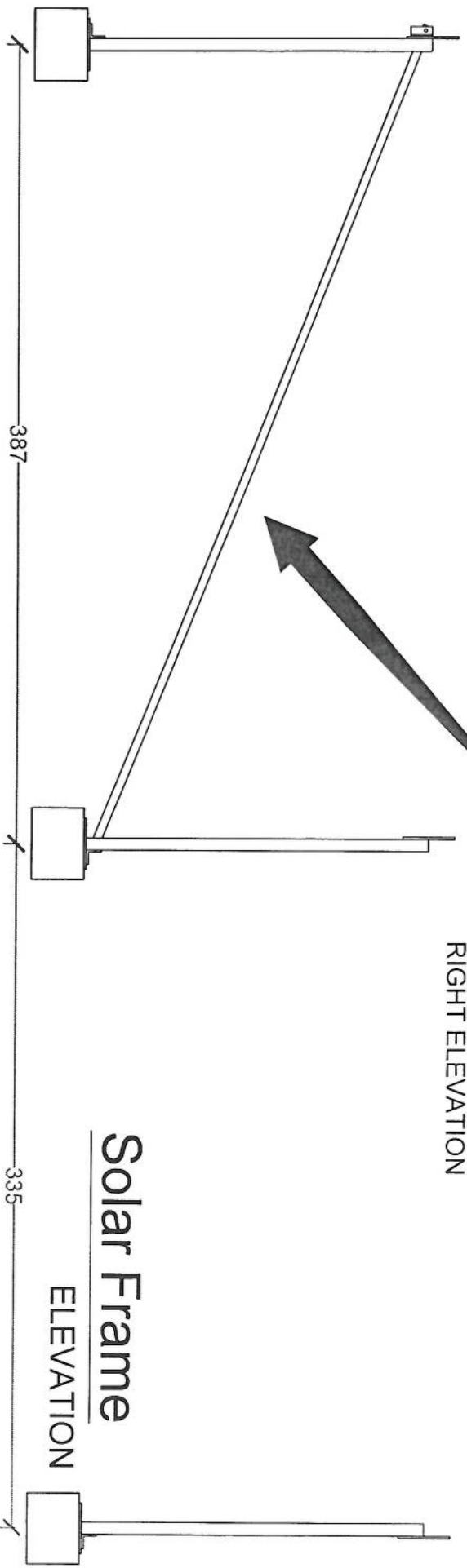
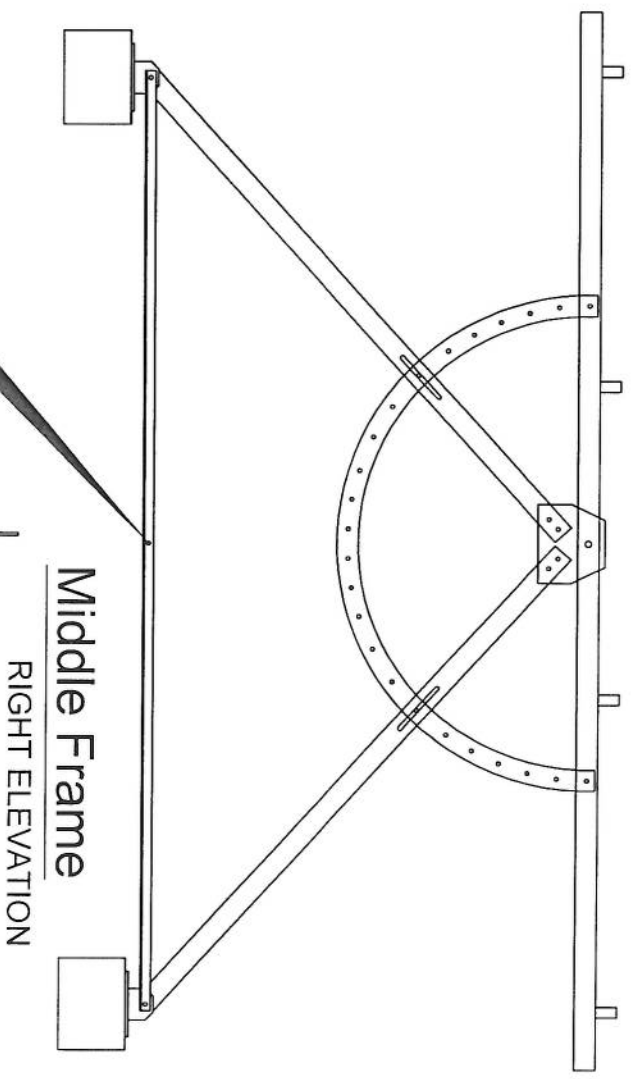
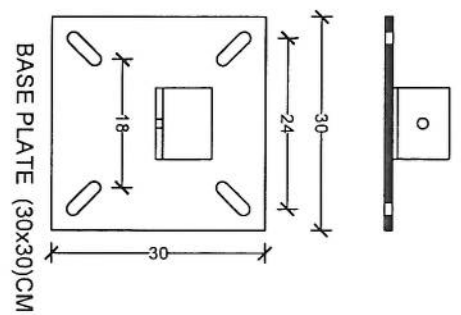

*Handwritten signature or initials in blue ink.*

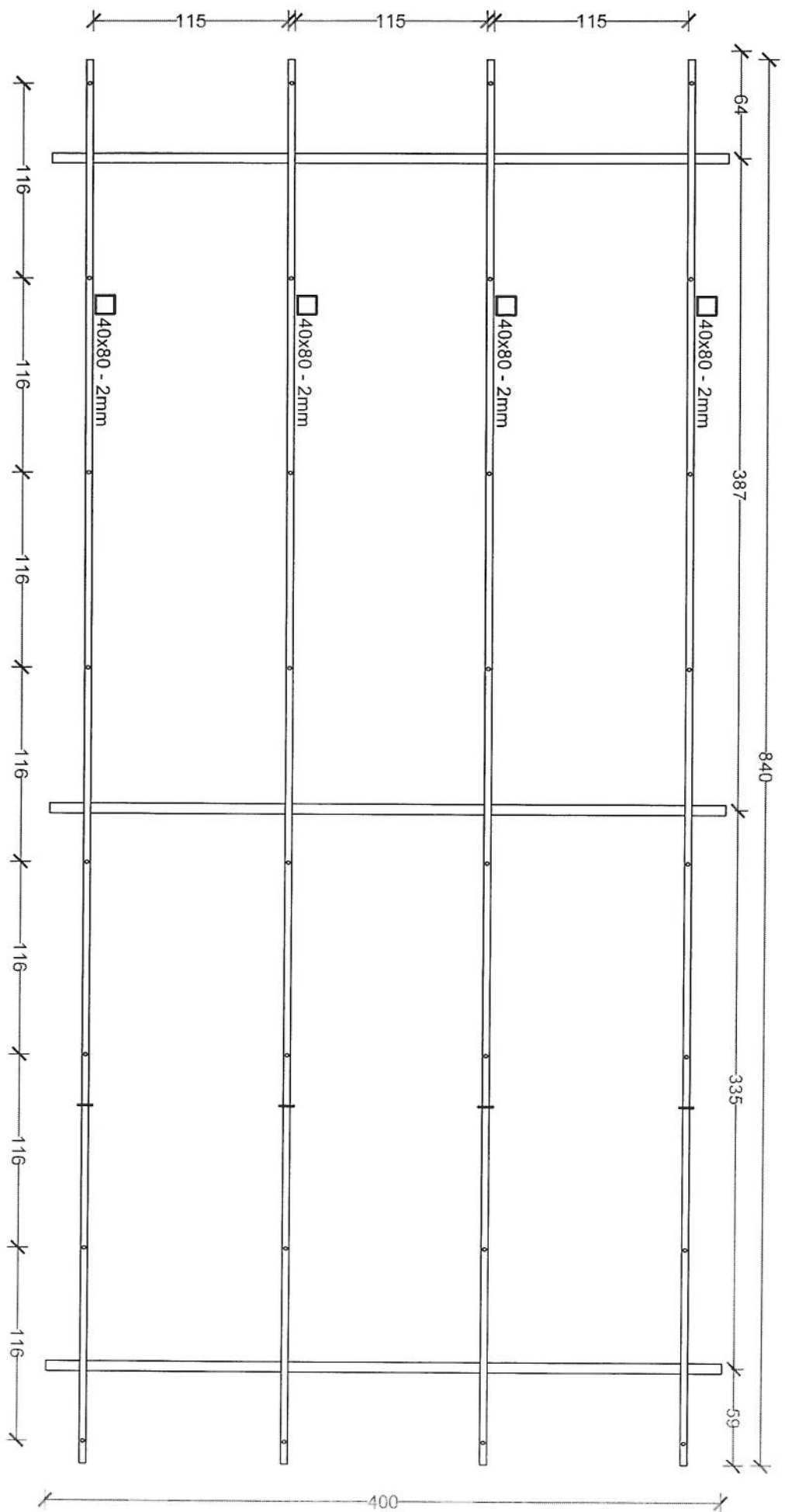

# 14 Plate Solar

Dimensions (113x227)CM

*[Handwritten signature]*

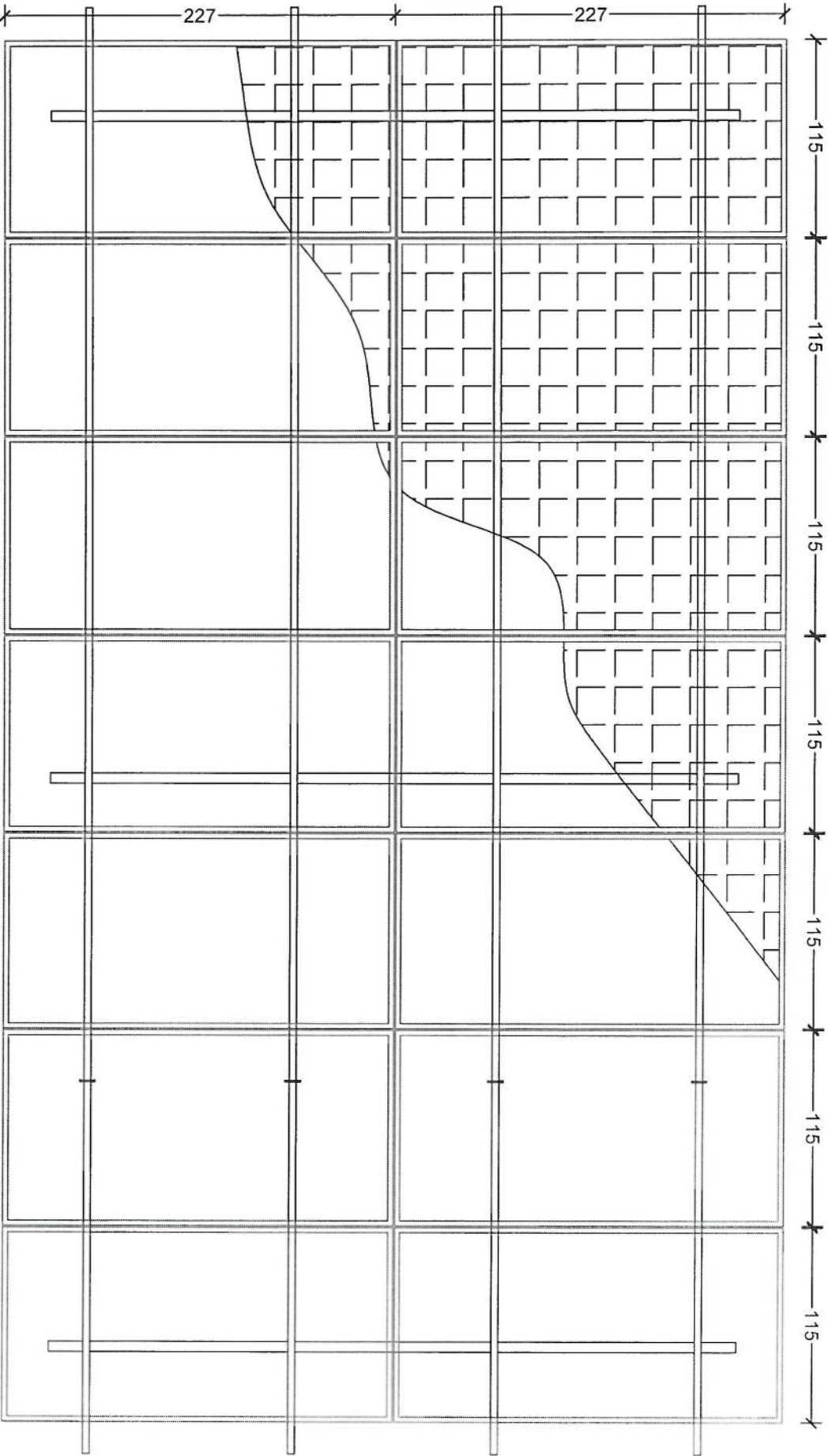

# 14 Plate Solar

Dimensions (113x227)CM

*Handwritten signature*

Handwritten signature or initials in blue ink, possibly reading "S. S. S." or similar, with a circular flourish below it.

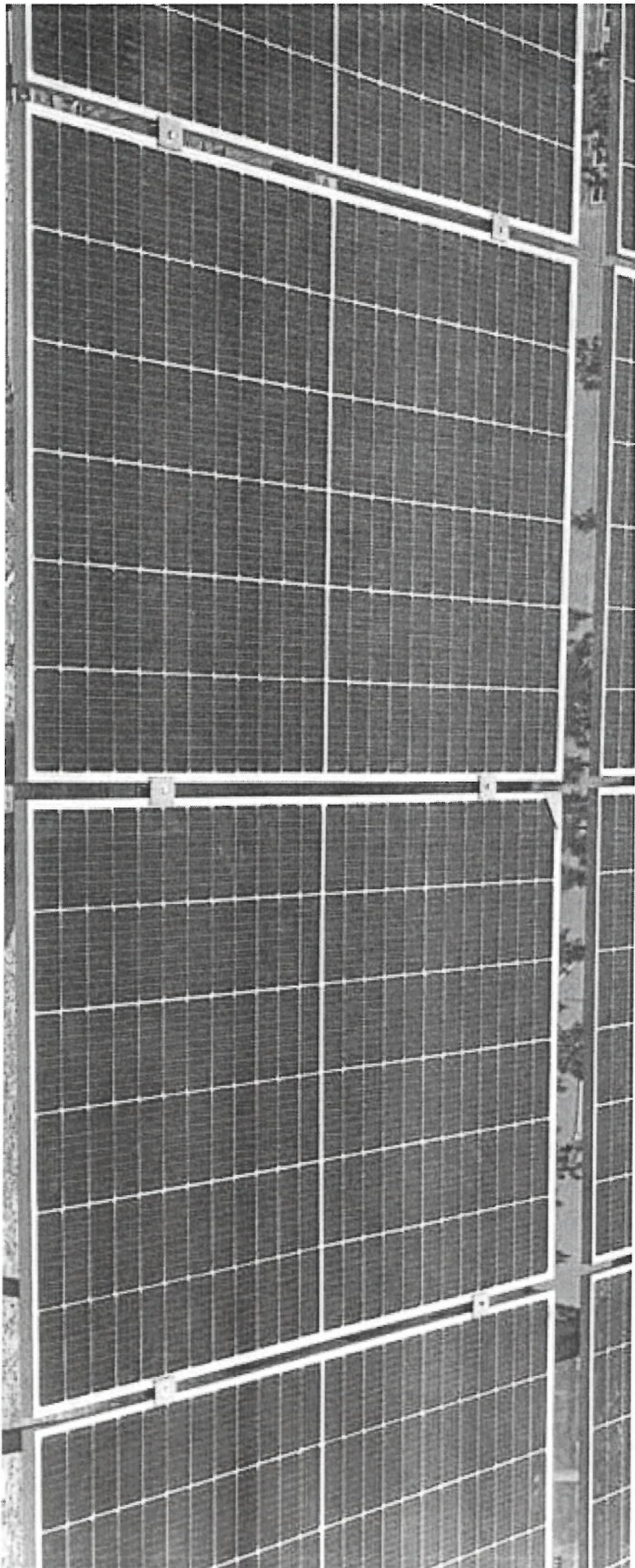

Faint, illegible handwritten text or a signature in the bottom right corner of the page.

Project No.:	Tower Type: TOWER NB		
Scale: 1/11	Ref. No. 00	Sheet No. 1	
Title:		NB TOWER 30M PANEL 1	
Project:		AFGHAN TELECOM	
Client:		TOWERIST	
Rev. 00	Design --	Drawn S. Ghodifi	Checked --
	Approved A. Solohour	Date 10/13/24	Description --

*Handwritten signature in blue ink.*

Qty	Specification
168	M12*40
48	M16*55

SEC. 10-10

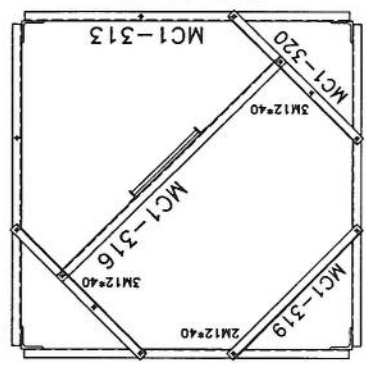

SEC. 9-9

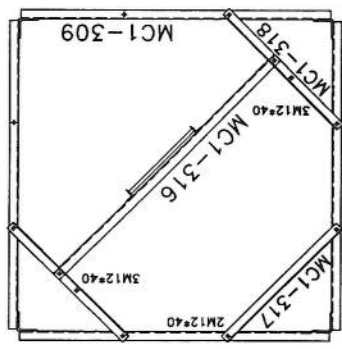

SEC. C-C

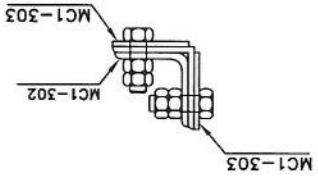

SEC. 8-8

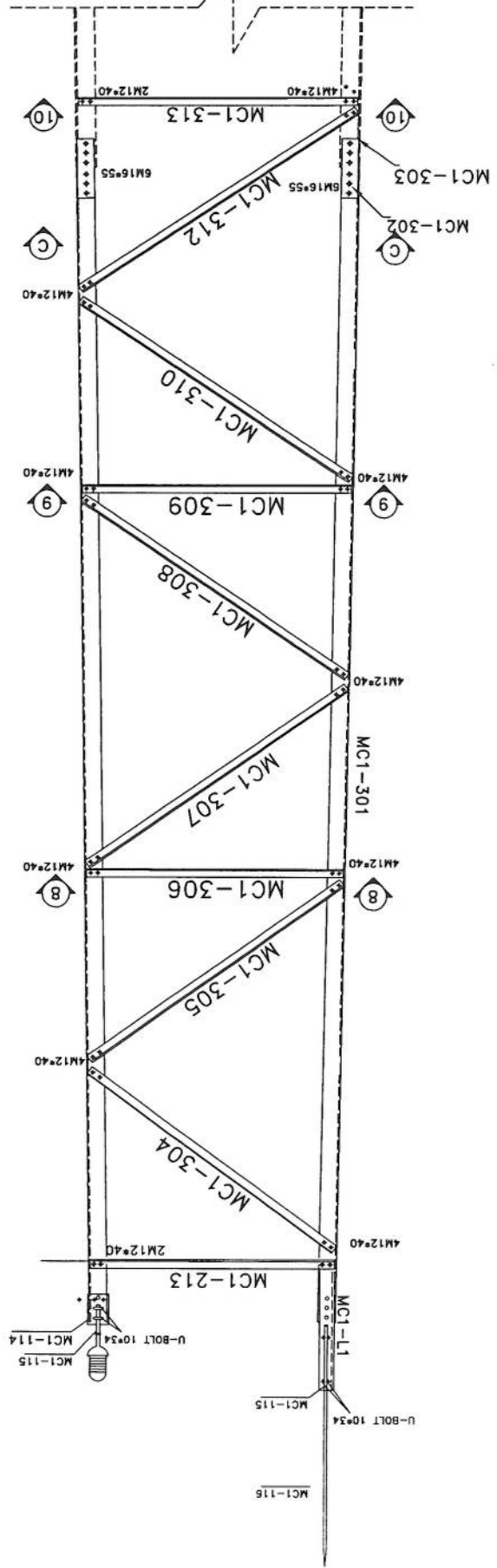
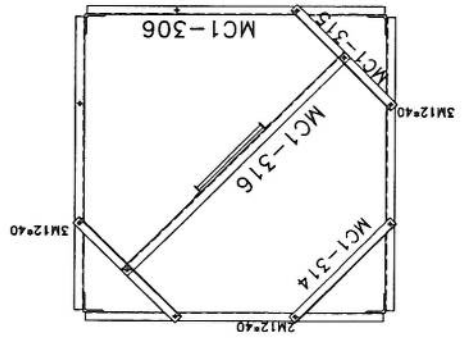

M12\*40

M12\*40

M12\*40

M12\*40

M12\*40

M12\*40

M12\*40

M12\*40

M12\*40

M12\*40

M12\*40

M12\*40

M12\*40

M12\*40

M12\*40

M12\*40

M12\*40

M12\*40

M12\*40

*Handwritten signature*

SEC. D-D

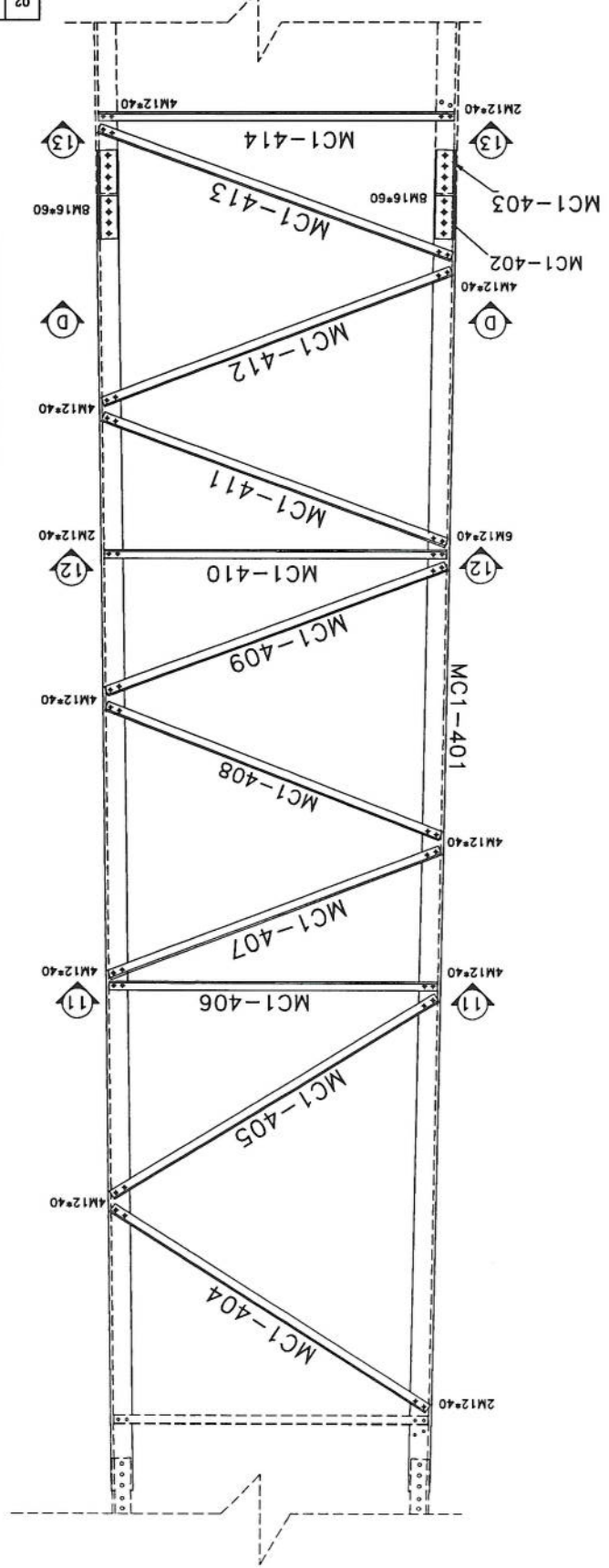
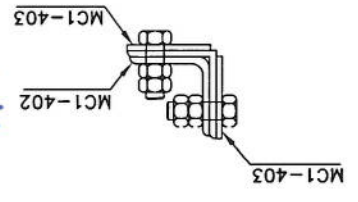

Project No.:		Scale: 1/11		Ref. No. 00		Sheet No. 2	
Tower Type: TOWER NB		Title 1					
Client 1		NB TOWER 30m					
Project 1		AFGHAN TELECOM					
Client 1		AFGHAN TELECOM					
Rev.	Design	Checked	Approved	Date	Description		
00	S. Ghodiri	---	A. Solahour	13/2024	---		
01	---	---	---	---	---		
02	---	---	---	---	---		

List of Bolts - PANEL 4

64	M16x60
200	M12x40
	Specification
	Qty

SEC. 13-13

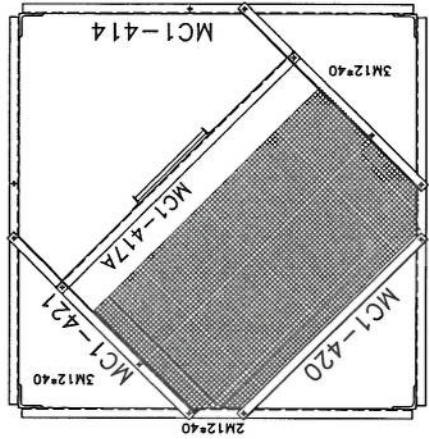

SEC. 12-12

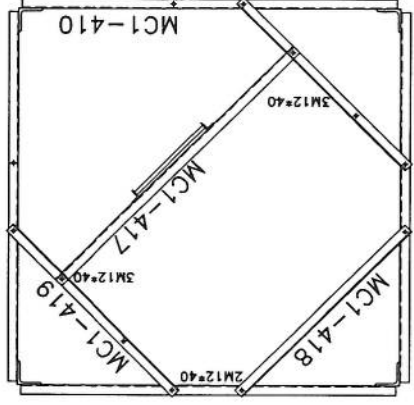

SEC. 11-11

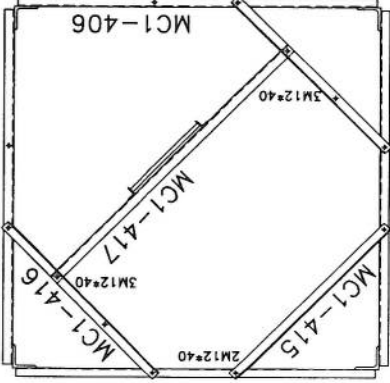

Project No.: _____		Scale: 1/11		Ref. No. 00		Sheet No. 5	
Tower Type: TOWER NB		Title: NB TOWER 30M PANEL 3					
Client: _____		Project: AFGHAN TELECOM					
Rev.		Design		Drawn		Checked	
00		---		S.Sherif		---	
01		---		---		---	
02		---		---		---	
Rev.		Description		Date		Approved	
---		---		10/13/24		A.Solihour	



80	M16x60
194	M12x40
Qty	Specification
List of Bolts - PANEL 5	

SEC. 16-16

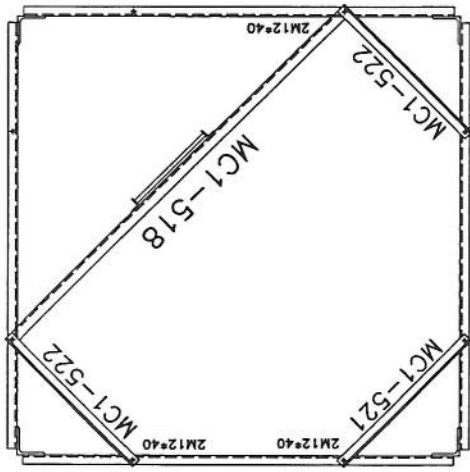

SEC. 15-15

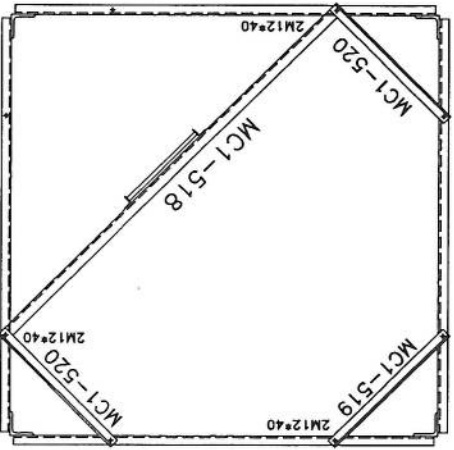

SEC. 14-14

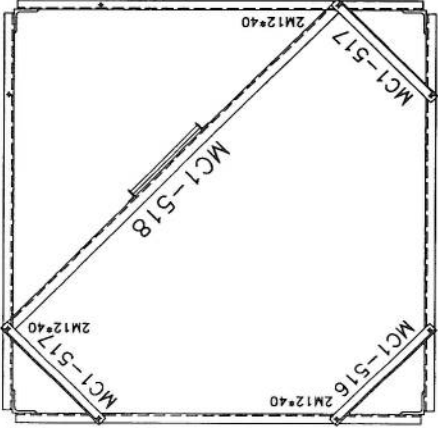

SEC. E-E

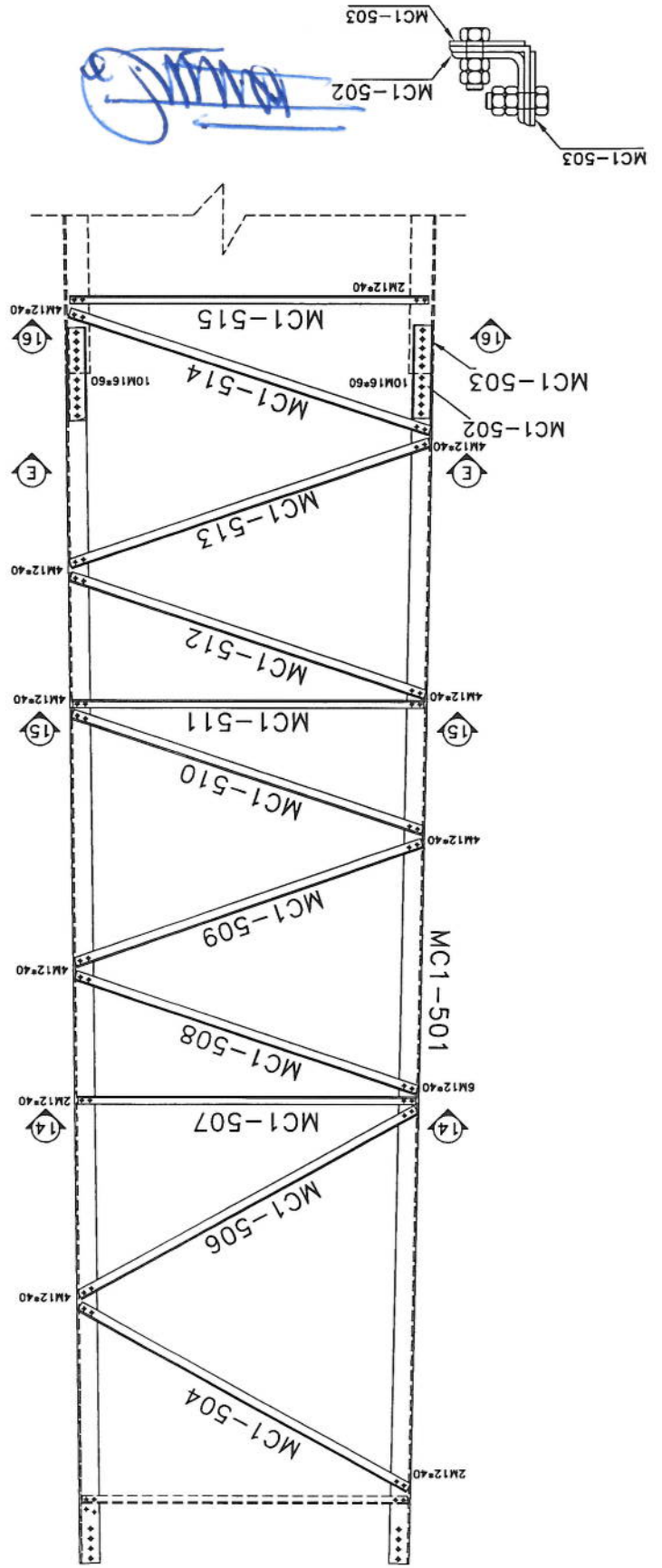

Project No.:		Sheet No. 5	
Tower Type: TOWER NB		Ref. No. 00	
Title 1		Scale: 1/11	
Project 1		NB TOWER 30M	
Client 1		PANEL 4	
AFGHAN TELECOM			
Rev.	Design	Checked	Description
00	S. Ghodiri	A. Solohour	10/13/24
01			
02			



SEC. F-F

*[Handwritten signature]*

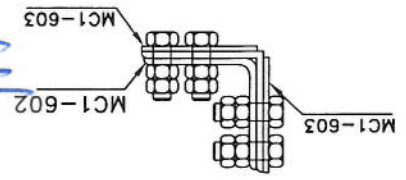

List of Bolts - PANEL 5

Specification	Qty
M12x40	186
M12x45	24
M16x65	96

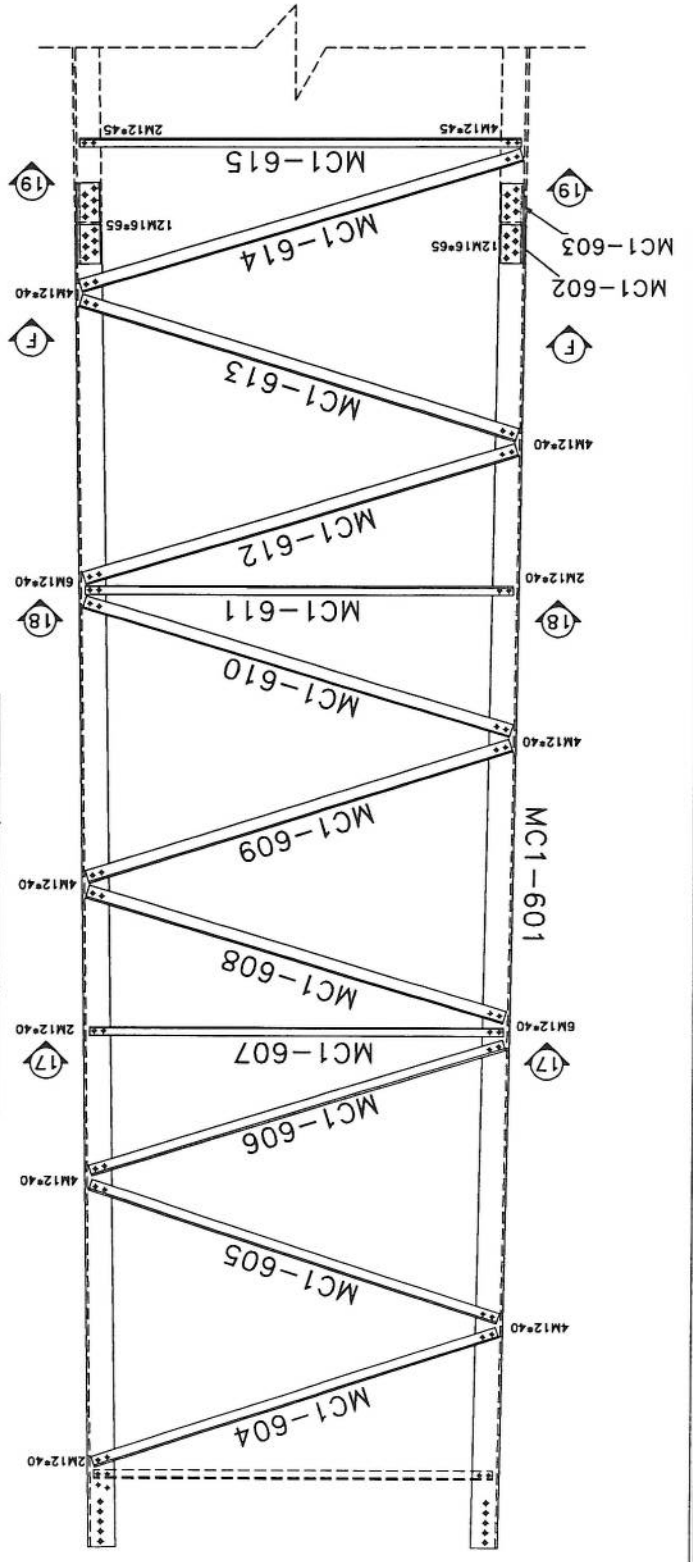
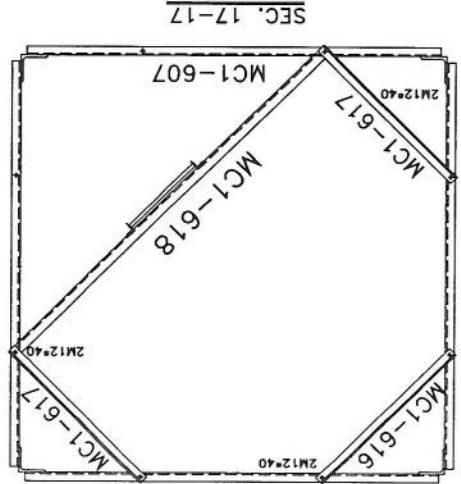
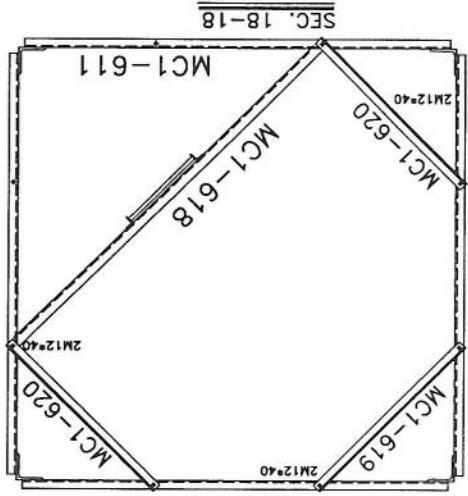
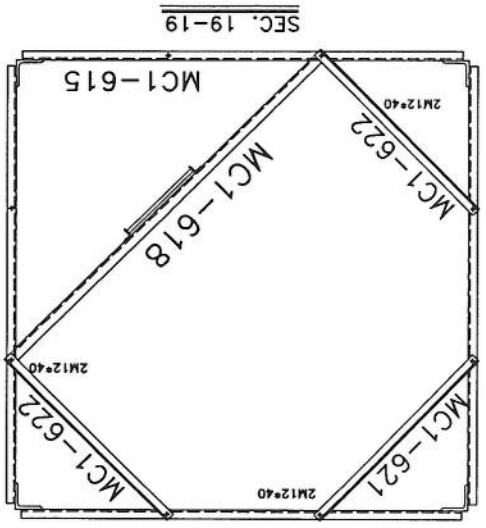



*Handwritten signature*

GENERAL VIEW

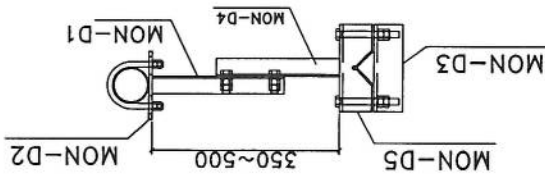

BILL OF MATERIAL GSM

ASSEMBLY	POSITION	SIZE	QUANTITY
MON-D3	PLB		2
ARM-1	MON-D1	UNP80	2
ARM-1	MON-D2	PLB	2
	MON-D4	UNP80	2
ARM-2	MON-D5	PLB	2
	MON-D6	PIPE60*1.3	1
BOLT	M16*300	-	8
UBOLT	M12*130	-	4

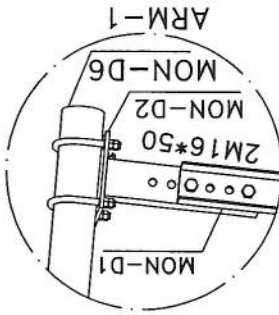

GENERAL VIEW

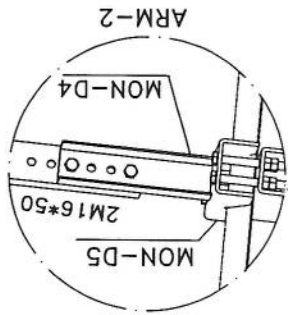
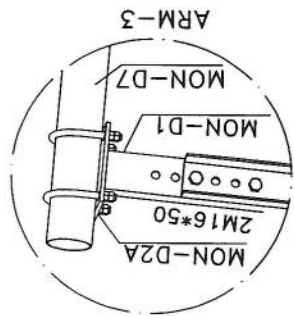
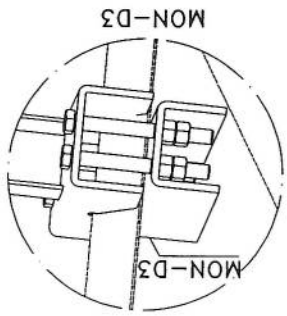
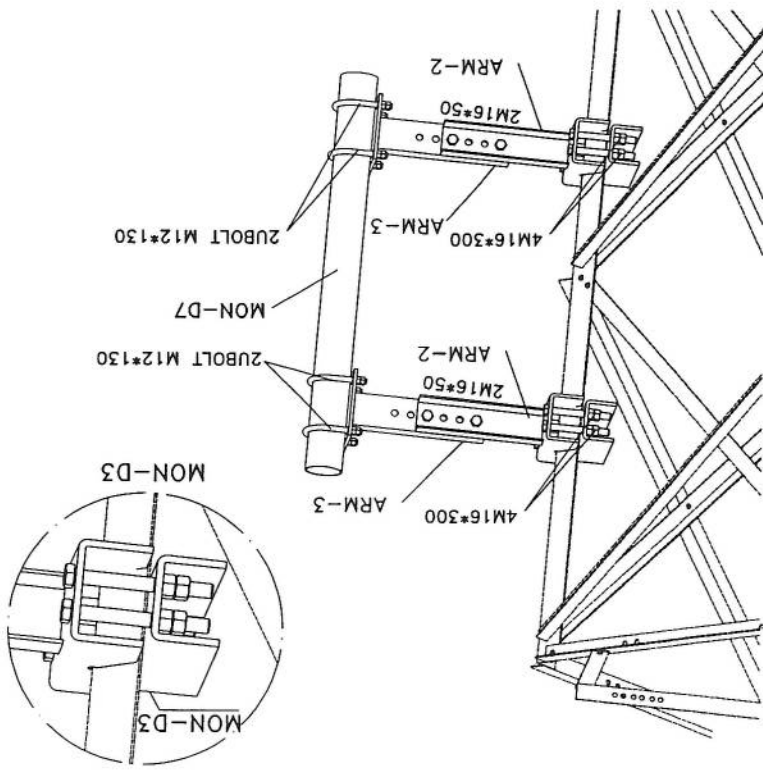
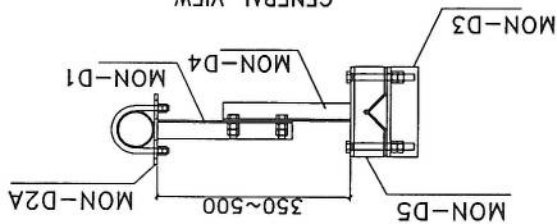

BILL OF MATERIAL MW

ASSEMBLY	POSITION	SIZE	QUANTITY
MON-D3	PLB		2
ARM-3	MON-D1	UNP80	2
	MON-D2A	PLB	2
ARM-2	MON-D5	PLB	2
	MON-D7	PIPE115*1.5	1
BOLT	M16*300	-	8
UBOLT	M12*130	-	4

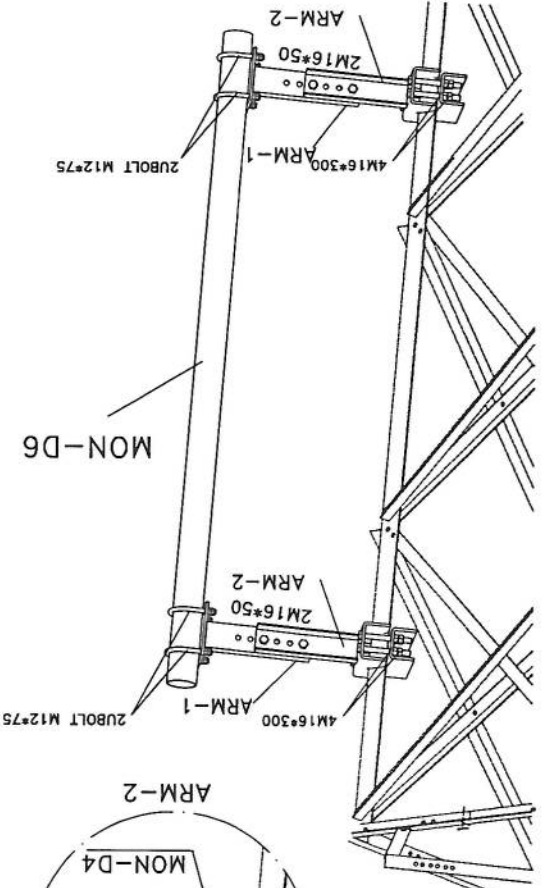

Project No.:	Scale: 1/11	Ref. No.:	00	Sheet No.:	12
Tower Type: TOWER MB		Title: NB TOWER 30M MOUNTING			
Client: AFGHAN TELECOM		Project: NB TOWER 30M MOUNTING			
Rev.	Design	Drawn	Checked	Approved	Date
02	S.Ghadih	A.Schahour	---	A.Schahour	01/03/11
01	S.Ghadih	A.Schahour	---	A.Schahour	01/02/24
00	S.Ghadih	A.Schahour	---	A.Schahour	10/13/24
Description					

Project No.: 1/11		Ref. No. 00		Sheet No. 12	
Tower Type: TOWER NB		Title: NB TOWER 30M PLATFORM 3M			
Client: AFGHAN TELECOM		Project: AFGHAN TELECOM			
					
Rev.	Design	Drawn	Checked	Approved	Date
00	--	S.Ghafari	--	A.Salahour	10/13/24
01	--	S.Ghafari	--	A.Salahour	01/02/24
02	--	S.Ghafari	--	A.Salahour	01/03/11
Description					



6	RBM10x50
6	M12*45
Qty	Specification
List Of Bolts - LADDER	

SECTION A-A

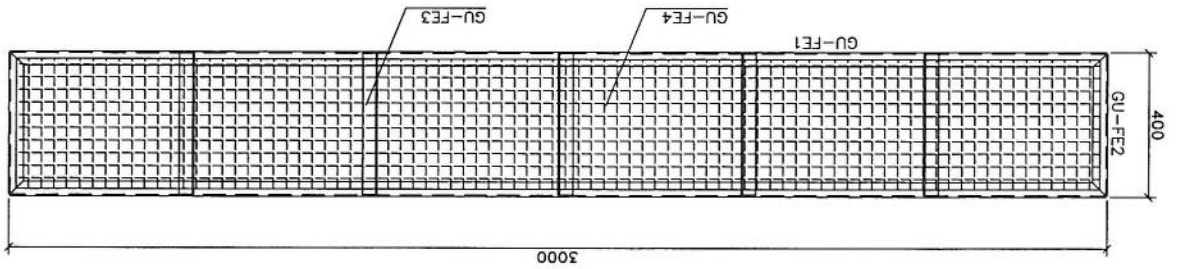
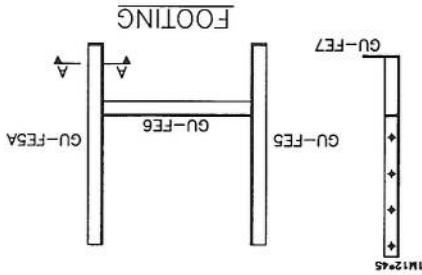
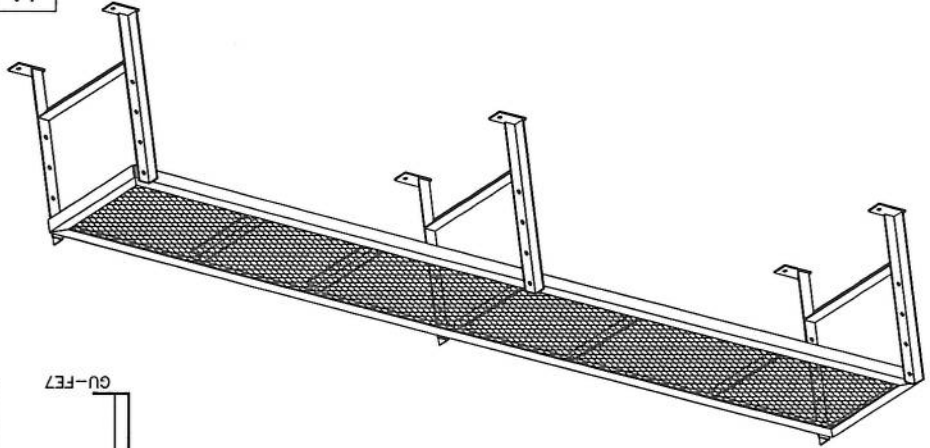
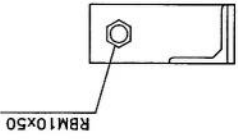



*[Handwritten signature]*



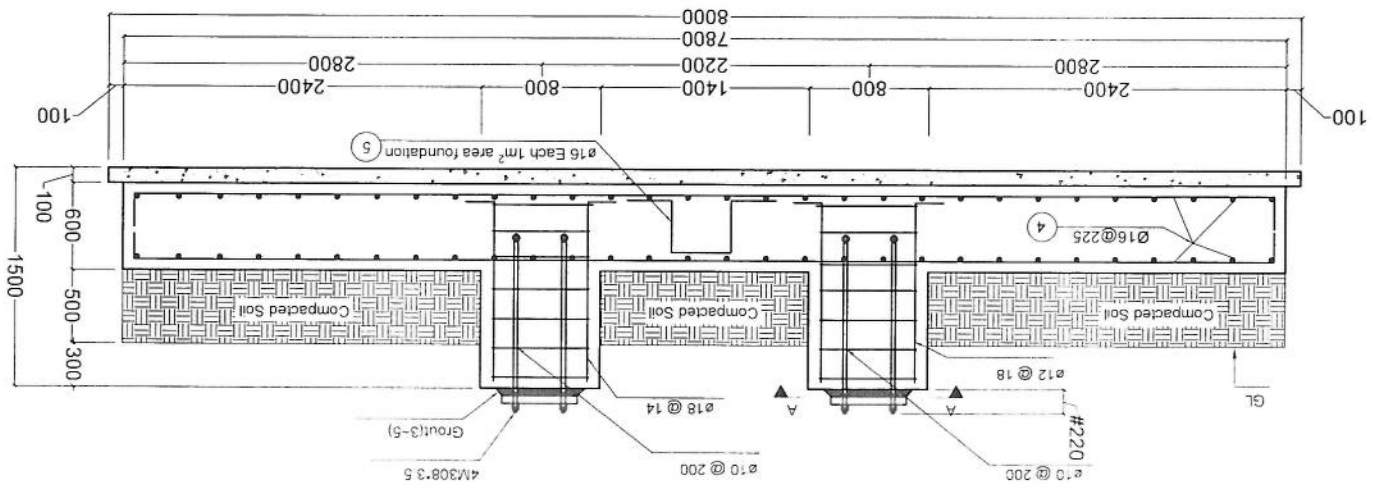
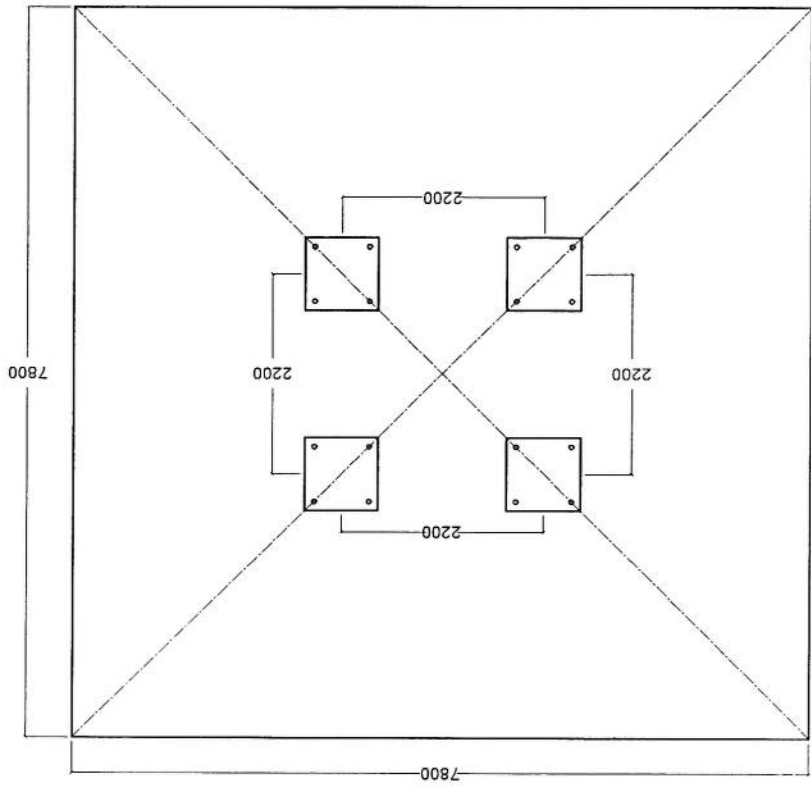
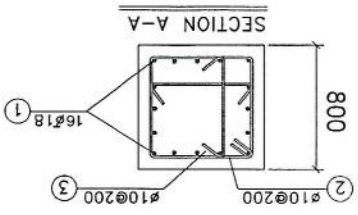
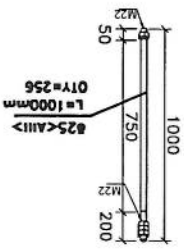
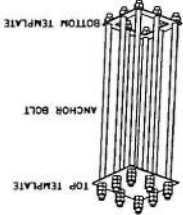

Bill of Material						
Pos	Shape	Dia(mm)	Length(m)	Quantity	Total Length(m)	Total Weight
1		18	1.50	64	96	192
2		10	2.8	28	79.00	49
3		10	0.85	56	48.00	30
4		16	8.15	140	1203	1741
5		16	2.20	59	130	204
Concrete Volume : 38.55 m <sup>3</sup>				Total Weight = 2216 kg		

- Notes:
- All Dimensions are in mm.
  - F<sub>c</sub> of concrete = 250 kg/cm<sup>2</sup>.
  - F<sub>y</sub> of longitudinal Bars = 4000 kg/cm<sup>2</sup>.
  - Cover = 7.5 cm.
  - Soil Allowable Stress = 1.5-2 kg/Cm<sup>2</sup>.
  - Concrete to be poured max in tow stages.
  - Concrete to confirm the specification.



REVISION RECORDS	
REVISION NO	DATE / DESCRIPTION

LEGEND:

 PVC  
 Soft Soil  
 Salt and Charcoal  
 Copper Plate 600\*600\*3mm

PROJECT TITLE / NO:  
GSM SITES  
عنوان پروژه: GSM سایت های موبایل

DRAWING TITLE:  
30m Tower Grounding System  
سیستم ارتداد برای دکل 30 متری

DRAWN BY:  
CIVIL TEAM

CHECKED BY:

APPROVED BY:

SCALE: 1:75  
ACTUAL DATE: 14/05/2025  
ISSUE DATE: DRG.NO: 23

OWNER: AFGHAN TELECOM  
Salam Telecommunication Company  
KABUL AFGHANISTAN

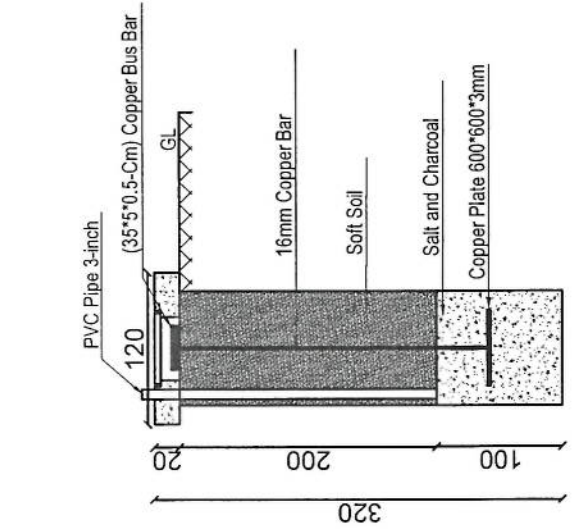

Detail-A Well Section

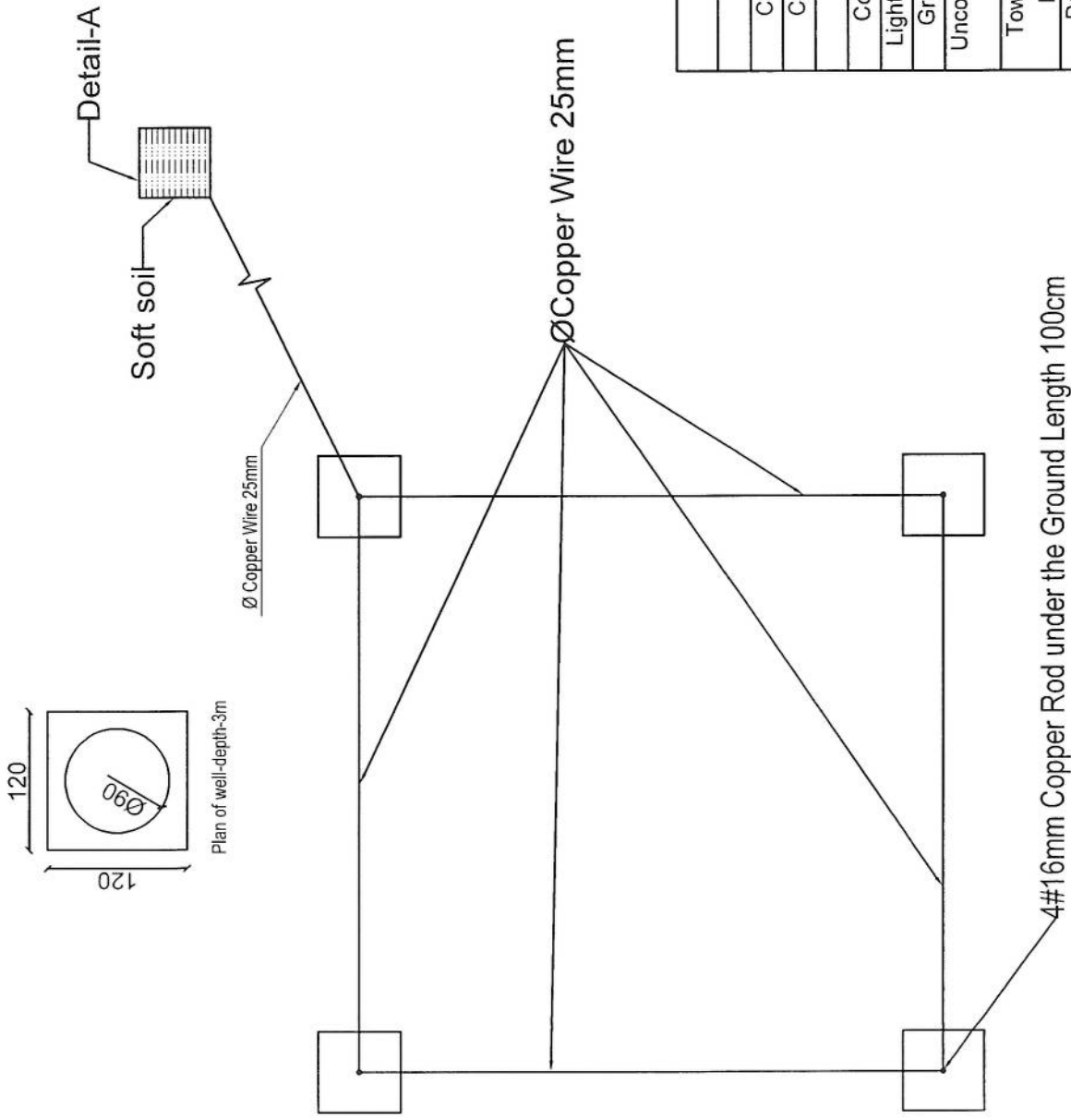

Item	Quantity	Dimension
Copper Rod	4 Pcs	1m * Ø16mm
Copper Rod	1 Pcs	2m * Ø16mm
Busbar	5 Pcs	35cm * 5cm * 5mm
Copper Plate	1 Pcs	60cm * 60cm * 3mm
Lightning Arrestor	1 Pcs	1m
Ground Cable	45m	25mm
Uncovered Ground Cable	12m	25mm
Tower Light with photo cell	1 Pcs	48V DC
Power Cable	50m	2*2mm

*[Handwritten signature]*